

# DELTA MEMBRANE SYSTEMS LTD

## DELTA CAVITY DRAIN SYSTEM

Date: April 2018



# CONTENTS

---

DELTA CAVITY DRAIN SYSTEM	03
A DELTA SOLUTION	04
DELTA MS500	06
DELTA MS20	07
DELTA PT	08
DELTA FM	09
ANCILLARY PRODUCTS	10
DRAINAGE OPTIONS	12
FREE LIME RISK	14
BASEMENT PROTECTION	15
DELTA PUMPS	16
ALARMS, MONITORING AND BATTERIES	23
SERVICING PLANS & COMMISSIONING	26
GUARANTEES	27

# DELTA CAVITY DRAIN SYSTEM

Delta Membrane Systems Limited is the leading Type C Cavity Drain Membrane Manufacturer in the United Kingdom. Our extensive range of waterproofing and damp proofing products are suitable for basement drainage and structural waterproofing (both for new build and existing structures) and in flood resilience projects.



Installing a Delta Membrane System offers complete protection to structures from ground water ingress and contaminates. Our products comply with British Standard BS 8102:2009 and are BBA Certified. Our dedicated Technical Team offer knowledge and experience in waterproofing design solutions, provide on-site assistance and advice throughout a project.



- Type C Drainage Protection in accordance with BS 8102:2009
- BBA Approved
- Suitable for new, existing and retrofit basement projects
- Ability to easily deal with aggressive ground water conditions
- "Grade 3" performance level (no dampness or water penetration acceptable)
- "Air Gap" Technology
- A reversible system, which will not create damage to historical or heritage structures
- Flexibility to cope in structures where movement or vibration issues can be problematic
- Virgin High Density Polyethylene studded/moulded sheet (HDPE)
- Easily applied to a variety of different substrates
- An effective barrier to the transmission of salts, liquid water and water vapour
- Suitable for Flood Resilience
- Can be recycled

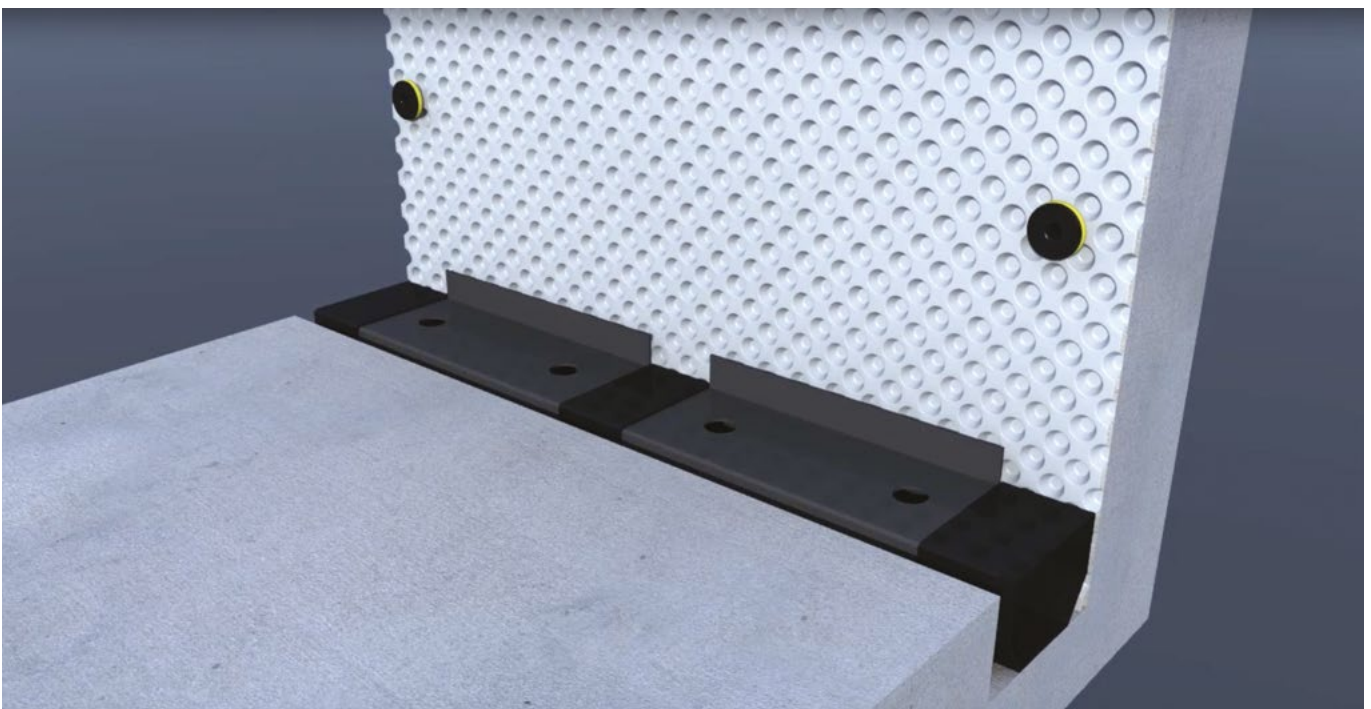

## BENEFITS OF A CAVITY DRAIN SYSTEM

In principle a cavity drain membrane system allows moisture or running water to travel behind the membrane within a controlled drainage system. A cavity drain system requires minimal preparation and disturbance to an existing substrate.

# A DELTA SOLUTION

BS 8102:2009 (Code of Practice for Protection of Below Ground Structures Against Water from the Ground) recommends that every Design Team should incorporate a Waterproofing Design Specialist.

Delta Membrane Systems Limited has a dedicated team of Waterproofing Design Specialists. Our trusted Technical Team offer knowledge and experience and are able to provide expertise in structural waterproofing. As a Waterproofing Specialist Manufacturer, we work with architects, surveyors, contractors and engineers alike to provide a design service which complies with BS 8102:2009 and offers the highest level of technical expertise and assurance.



## BELOW GROUND WATERPROOFING SOLUTIONS FOR:

- Residential Buildings
- Commercial Buildings
- Retail Units and Warehouses
- Leisure Facilities
- Archives/Libraries/Vaults
- Hospitals
- Schools
- Underground Rail Stations and Tunnelling
- Underground Car Parking areas
- Listed Buildings
- Heritage Buildings
- Insulated Formwork Construction (ICF)



# SERVICES

Delta Membrane Systems Limited provides a full range of waterproofing solutions suitable for all new, retrofit and refurbishment construction. With over 125 years of manufacturing experience Delta is an impeccable partner on every project. Our skills have been mastered through experience in the waterproofing industry. Delta's trusted Technical Team will offer assistance from concept to completion. Our hands on approach and knowledge is what sets us apart.



## DESIGN SUPPORT

- Architecture knowledge
- Concept and waterproofing solutions
- Advice on design and best practice
- Custom solutions, as each project is unique in requirements
- Qualified CSSW staff (named on the Waterproofing Design Register)



## SPECIFICATION SUPPORT

- Detailed drawings including CAD
- Watertight and locking down structure concepts
- Specifications
- BIM
- NBS Plus
- RIBA Product Selector



## SITE SUPPORT

- Training and guidance offered at every step
- Technical Team attendance at site meetings
- Knowledge and experience
- Troubleshooting solutions



# DELTA MS500

Delta MS500 is an 8mm studded profile High Density Polyethylene (HDPE) clear cavity drainage membrane. It is suitable for use on the internal faces of walls and floors as a water management system for the protection of below ground structures against the potentially adverse effects of ground water ingress.

- Type C Drained Protection in accordance with BS 8102:2009
- BBA Approved
- Suitable for new, existing and retrofit basement projects
- Flexibility to cope in structures where movement or vibration can be problematic
- A "reversible" system, which will minimise damage to historical or heritage structures
- An effective barrier to the transmission of salts, liquid water and water vapour
- Resistant to chemicals, root penetration, rot proof and neutral towards drinking water
- Suitable for Flood Resilience
- Resistant to Carbon Dioxide, Radon and Methane

## SPECIFICATION

NBS Specification J40  
(Clause 290)  
Flexible Sheet Tanking/Damp  
Proofing.

BS 8102:2009 Type C Drained  
Protection.



## TECHNICAL DATA

Material:	High Density Polyethylene (HDPE)
Sheet Thickness:	0.5 mm
Stud Height:	8 mm
Roll Size:	2.4 x 20m 2.0 x 20m
Compressive Strength:	>250 kN/M <sup>2</sup>
Drainage Capacity:	2.25 L/S M 135 L/MIN M 8 100 L/H M
Air volume between studs:	5.3 L/M <sup>2</sup>
Temperature Resistance:	-30°C to +80°C
Reaction to Fire:	EN13501-1 Class E
R Value	0.12 M <sup>2</sup> K/W



# DELTA MS20

Delta MS20 is a High Density Polyethylene (HDPE) high drainage cavity drain membrane with superior drainage capacity and compressive strength. Delta MS20 is suitable for use as a high performance water control and management system in building and civil engineering construction. A superior solution for waterproofing basement floors and walls.

- Type C Drained Protection in accordance with BS 8102:2009
- BBA Approved
- Suitable for higher volumes of water penetration
- A reversible system, which will minimize damage to historical or heritage structures
- An effective barrier to the transmission of salts, liquid water and water vapour
- Resistant to chemicals, root penetration, rot proof and neutral towards drinking water
- Suitable for Flood Resilience
- Resistant to Carbon Dioxide, Radon and Methane

## SPECIFICATION

NBS Specification J40  
(Clause 290)  
Flexible Sheet Tanking/Damp  
Proofing.

BS 8102:2009 Type C Drained  
Protection.



## TECHNICAL DATA

Material:	High Density Polyethylene (HDPE)
Sheet Thickness:	1 mm
Stud Height:	20 mm
Roll Size:	2.0 x 20m
Compressive Strength:	150 kN/M <sup>2</sup>
Drainage Capacity:	101 L/S M 600 L/MIN M 36 100 L/H M
Air volume between studs:	14 L/M <sup>2</sup>
Temperature Resistance:	-30°C to +80°C
Reaction to Fire:	EN13501-1 Class E
R Value	0.18 M <sup>2</sup> K/W



# DELTA PT (INCLUDING DELTA PT/PLASTER LATH AND DELTA PT SLIMLINE)

Delta PT is a High Density Polyethylene (HDPE) cavity drain membrane. Delta PT has been designed with a plastic mesh which is welded to the surface of this dimpled sheeting membrane. Suitable as an impermeable damp proofing base for plaster or shotcrete (and as a water control and drainage membrane) in tunnel construction or for remedial damp proofing and waterproofing of existing basements internally.

- Type C Drained Protection in accordance with BS 8102:2009
- BBA Approved
- A reversible system, which will minimize damage to historical or heritage structures
- An effective barrier to the transmission of salts, liquid water and water vapour
- Available in 3 stud heights
- Resistant to chemicals, root penetration, rot proof and neutral towards drinking water
- Suitable for Flood Resilience
- Resistant to Carbon Dioxide, Radon and Methane
- Neutral towards drinking water

## SPECIFICATION

NBS Specification J40  
(Clause 290)  
Flexible Sheet Tanking/Damp Proofing.

BS 8102:2009 Type C Drained Protection.

### DELTA PT PROFILE

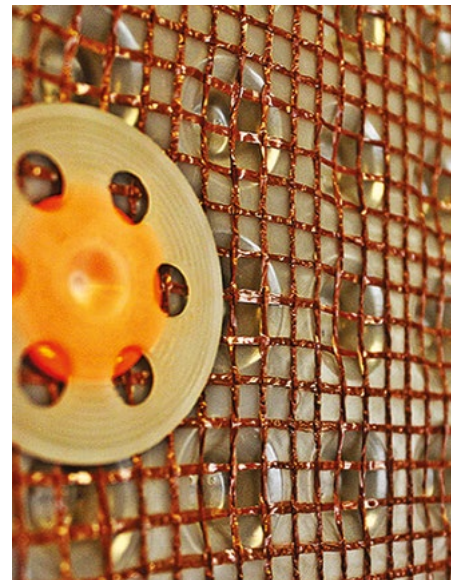
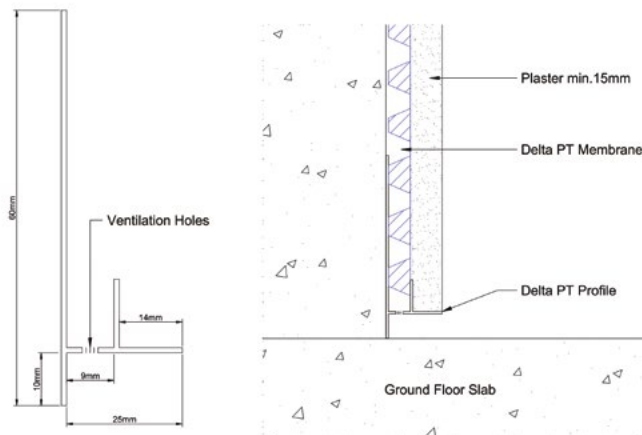

## TECHNICAL DATA

Material:	High Density Polyethylene (HDPE)
Sheet Thickness:	0.5mm
Stud Height:	8 mm/ 7 mm/ 4mm options
Roll Size:	2.0 x 20m/ 1.5 x 10m/ 1.0 x 15m
Compressive Strength:	70 kN/M <sup>2</sup>
Drainage Capacity:	5 L/S M 300 L/MIN M 18 100 L/H M
Void between studs:	5.5 L/m <sup>2</sup>
Temperature Resistance:	-30°C to +80°C
Reaction to Fire:	EN13501-1 Class E





# DELTA FM

Delta FM is a Virgin High Performance PE-VHD. Specifically designed for floor applications to combat capillary dampness and contamination. The low stud profile (4.5 mm) minimises the impact upon existing floor levels but still provides an air gap to achieve damp pressure equalisation. The special low profile offered by Delta FM is excellent for detailing existing staircases and tight spaces. Delta FM can be linked to other Delta MS membranes.

- A fast-track application which allows for various floor finishes to be achieved with zero 'down time'.
- Type C Drained Protection in accordance with BS 8102:2009
- BBA Approved
- Relative humidity levels are isolated in the air gap and controlled
- A reversible system, which will minimize damage to historical or heritage structures
- An effective barrier to the transmission of salts, liquid water and water vapour

## SPECIFICATION

NBS Specification J40  
(Clause 290)  
Flexible Sheet Tanking/Damp Proofing.

BS 8102:2009 Type C Drained Protection.

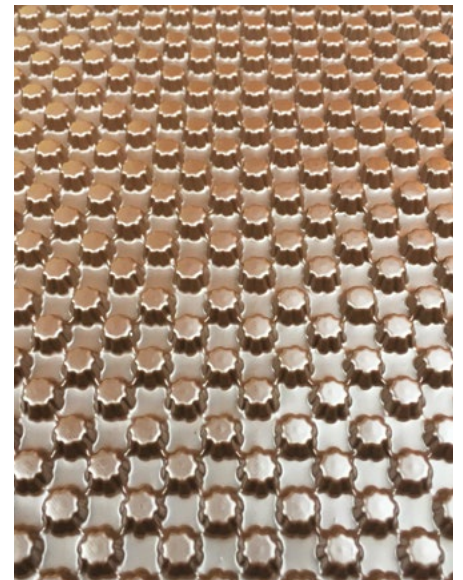

## TECHNICAL DATA

Material:	Virgin high-performance PE-VHD
Application:	Special low stud profile for floor. Can be used on walls
Sheet Thickness:	0.6 mm
Stud Height:	4.5 mm
Roll Size:	2.0 x 2 m (40m <sup>2</sup> )
Compressive Strength:	700 KN/M <sup>2</sup>
Air volume between Dimples:	2.6 L/M <sup>2</sup>
Temperature Resistance:	-30°C to +80°C
Reaction to Fire:	EN13501-1 Class E



# ANCILLARY PRODUCTS

Our range of ancillary products work as the perfect compliment to the Delta Cavity Drain System. Allowing for application on different substrates and surfaces both sealing the membranes and detailing with any provisions whilst preventing condensation.



**DELTA PLUGS**

Provides a fixing point for our Delta MS500 membrane. Delta fixing plugs when used in conjunction with Delta Rope offer a watertight seal. These plugs have a centrally located internal shank which accommodates a 5.5mm dia./size 12 screw at a maximum depth of 30mm for subsequent installation of wall ties and/or dry lining systems (11mm shank x 70mm).



**DELTA QWIK-SEAL PLUGS**

A watertight self-sealing fixing plug suitable for our MS500 or PT membranes. These plugs have a centrally located internal shank that can accommodate a 5mm dia./size 10 screw at a maximum depth of 30mm for subsequent installation of wall ties and/or dry lining systems (10mm shank x 58mm).



**DELTA PT PLUGS**

A watertight self-sealing fixing plug which works in harmony with our PT or PT Slimline membranes. Delta PT Plugs are available with or without grommets. Grommets allow for a watertight, self-sealing finish. Delta rope can be used as an alternative to grommets to give a watertight finish (8mm shank x 52mm).



**DELTA FLEXIDRI PLUGS**

Patented expandable fixing plugs which offer extra grip and are unique to Delta Membrane Systems Limited. Delta FlexiDri Plugs are suitable for both Delta MS500 and Delta PT membranes. These fixing plugs have a centrally located pin which when inserted expands to allow the plug a firm grip into the substrate. The pin has an internal shank that accommodates a 5mm dia. screw for subsequent installation of wall ties and/or dry lining systems (10mm shank x 90mm).



**DELTA FLEXIDRI PLUS PLUGS**

Patented expandable watertight fixing plugs that have an additional self-sealing grommet, meaning no need for additional Delta rope. Delta FlexiDri Plus Plugs are unique to Delta Membrane Systems Limited. These fixing plugs have a centrally located watertight pin which when inserted expand to allow the plug to give a firm grip into the substrate. The pin has an internal shank that accommodates a 5mm dia./size 10 screw at a maximum depth of 30mm for subsequent installation of wall ties and/or dry lining systems (10mm shank x 90mm).



**DELTA PT PROFILE VENTILATION STRIP**

Delta PT Profile Ventilation Strip is designed for use with our meshed membranes. PT Profile Ventilation Strip is suitable for both upper and lower application to the membrane. This niche profile strip has ventilation slots incorporated to the design ensuring optimum ventilation is achieved behind the membrane. The profile section also acts as a guide or stop bead for plaster or render coats. Delta PT Profile Ventilation Strip is for suitable for above ground application (2m strip).



#### DELTA ROPE

Delta rope a robust and dependable product used for the application of sealing Delta plugs which do not have grommets. Delta Rope is ideal for sealing joints in MS20 and stud to stud joints in other Delta Membranes (4.75m x 10mm).



#### DELTA CORNER STRIP

Delta Corner Strip is a waterproof, firm and lasting single-sided sealing tape, applied to seal wall to floor junctions. Delta Corner Strip creates a vapour seal, an ideal solution for patch repairs and detailing around service penetrations (150mm x 20m).



#### DELTA FLEECE TAPE

Delta Fleece Tape has been designed for use with our Delta PT membrane. This exceptional one-sided sealing tape with its fleece backing is ideal for plastering or rendering directly onto (100mm x 20m).



#### DELTA TAPE

Used for the application of joining membranes. This strong and durable double sided butyl tape is ideal for sealing membranes together at overlaps/ adjacent seals (22.5m x 28mm).



#### DELTA PUDDLE FLANGE

A Delta Puddle Flange offers a waterproof seal when applying Delta Modular Drainage (Detail 129). A Delta Modular Drainage System prevents ground water percolating up between the 110mm pipe work/ RC slab or wall junction, reducing water ingress. The Delta Puddle Flange range is available in various sizes from 32mm to 160mm.



#### DELTA MS20 ACCESS PORT

Access ports allow for inspection of the drainage system and a suitable access for flushing (using a suitable lime solution). The MS20 Access Ports are supplied pre fixed into a rectangular piece of Delta MS20 which can be linked and sealed in the standard manner for our MS20 membranes.



#### DELTA MASTIC

Delta acrylic mastic is a universal mastic, ideal for sealing joints and detailing. Delta mastic is not suitable for use as a waterproof mastic.



#### DELTA THAN - WATERPROOF MASTIC

Delta Than is a superior waterproof mastic which is suitable for sealing joints and detailing.

**EVERYTHING YOU NEED**

We endeavour to offer you everything you need to complete a waterproofing installation.

If you can't find what you need, feel free to contact us.

# DRAINAGE OPTIONS

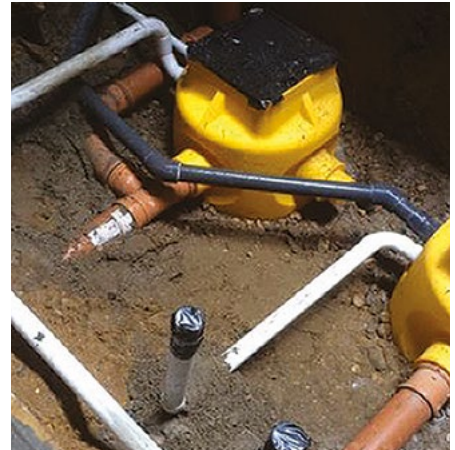

The concept of a Drained Cavity System is to collect and manage any ground water which breaches the integrity of a structure by managing, collecting and discharging such free water via a suitable evacuation point such as a Delta Packaged Pump Station.

Drainage options for a Delta Type C Drained Protection System include Delta Channel, Modular Drainage System or a combination of both. The Delta Drainage Channel as with the Modular Drainage System should ideally be recessed within the structural slab. Where this is not possible or practical, then a sacrificial screed bonded to the structural slab should be used to form a rebate for the perimeter Delta Channel.

Channels incorporated into the design and laid level allow water to drain by hydraulic gradient and can discharge passively any water ingress into a Delta Sump or other suitable discharge point, it is of course important to consider maintainability (BS 8102:2009 Section 10.3.1).

Delta offers a comprehensive range of Packaged Pump Stations which are suitable for the evacuation of Ground water, Surface water and Foul water. In addition we offer bespoke chambers for larger projects. Delta's sump pumps offer complete peace of mind.

Delta offers a full specification service for Package Pumps and Pump Stations by qualified drainage engineers specific to each project.



# DELTA CHANNEL

A Cavity Drainage System manages water penetration. Delta Channel is a water collection conduit designed to control water ingress in below ground applications. Delta Channel is bedded into a preformed recess/gully at the floor/wall junction and is suited for use in conjunction with the Delta Membrane range. Preformed holes within the Delta Channel allow for water to enter, then drain into a sump or suitable discharge point. Access points within the Delta Channel should be installed to allow for maintenance and inspection. The Delta Channel is joined by a range of accessories such as Straight Connectors, Corner Pieces, T Pieces and Drainage Channel End Caps. Where it is not possible to recess the channel into the structural slab we recommend speaking to Delta's Technical Team.

## SPECIFICATION

NBS specification R16  
(Clause 345)  
Ground water Pressure Relief  
Drainage

BS 8102:2009 Type C Drained  
Protection

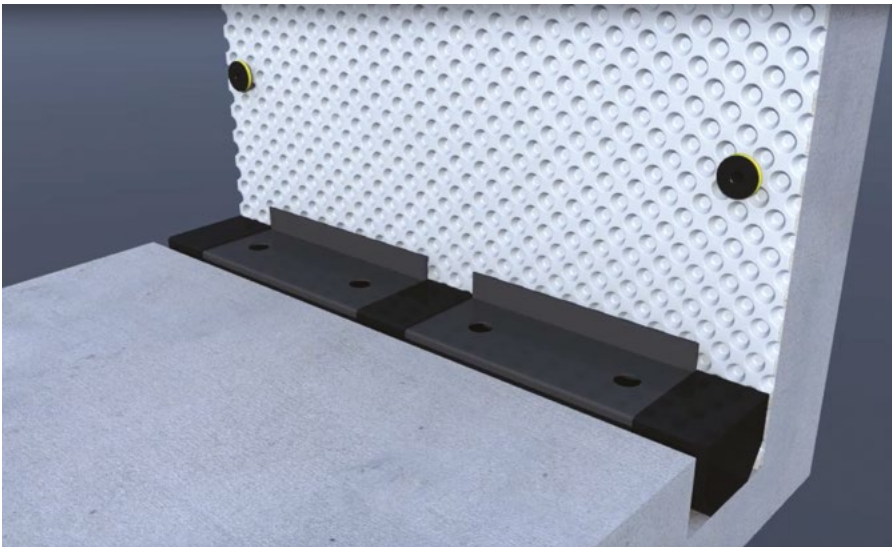

We recommend one Packaged Pump System should be installed for each 50 linear meters of Channel; the length of each Channel running to the Sump should not exceed 25m.

## MODULAR DRAINAGE METHOD

As an alternative to the Delta Channel, a Modular Drainage System may be considered using 110mm standard underground drainage pipe. As with all drainage systems it must be maintainable. We recommend contacting a member of Delta's Technical Team when utilising this method.



## DELTA AQUADUCT

Delta Aquaduct is a drainage pipe which acts as a perimeter conduit which is bedded into a preformed opening at the floor/wall junction. Where appropriate, it can be laid under the structural slab to drain ground water into a sump or soak away. Delta Aquaduct is fully perforated for maximum performance and incorporates an outer geotextile filter to prevent particles from entering the Channel. Delta Aquaduct is ideal for curved walls and around intricate details.

In addition, where appropriate it can be laid under the structural slab, thus reducing floating pressures from bearing on the slab.

Delta Aquaduct is available on a roll (150m x 60mm and 100m x 100mm).



# 'FREE LIME' RISK



The British Standard for waterproofing BS 8102:2009 recognises the requirement of a Type C Waterproofing System or Cavity Drain Membrane System to be maintainable.

The use of inspection ports within a Basement Waterproofing Design is key for maintenance or the ability to carry out periodic inspection. When new concrete is introduced to structures, there is a risk of excess free lime leaching out during the curing process in the form of calcium hydroxide, this free lime, if untreated, can enter the Cavity Drainage System which can impede the flow of water and cause sump pump failure. We recommend during a Cavity Drain System installation that a silicification pre-treatment of concrete be used to reduce the risk of free lime build up. Attention should be observed to dry pack joints often formed between the existing foundation and new concrete underpin, these are classic areas for free lime to infiltrate the structure and should be 'locked' down.

## KOSTER POLYSIL-TG 500

An 'anti lime' coating product specially blended with Polymers and silicates which is applied by brush or spray application. Applying Koster Polysil-TG 500 will not only reduce the amount of free lime leaching into the Cavity Drainage System but will also improve the water resistance of the basement structure by absorption into the structure and locking in the free lime.



# BASEMENT PROTECTION



One of the main design considerations when designing a Cavity Drain System is to consider managing the collection and discharge of ground and/or foul water.

The majority of projects will require a collection sump + pump to automatically manage the evacuation of water ingress. A sump + pump solution will require mains power to operate.

Peace of mind is offered with the MaxxFamily product range. The AlertMaxx2 is a high level water alarm and monitoring system which will predictively alert a home owner when there is a potential fault or service required to the sump pump. Our extensive range of battery back-ups offer unrivalled technology and will keep the sump pump working in the event of power failure.

The number of pump systems required for each project will (in part) depend on the overall basement size, perimeter and also the method of drainage – Delta Channel, Modular or a combination of both.

External surface water from light-wells, courtyards and terraces may be drained into the ground water sump, providing the area of external surface water collection does not exceed 12m<sup>2</sup> to each sump – if the external area is greater, advice should be sought from the Delta Technical Team.

For each sump system, the recommendation is for two pumps in case of failure of the duty pump. In the event of failure of the duty pump, the secondary back up pump will take over, therefore significantly reducing the risk of potential flooding. In addition a minimum industry standard would be to include a high level alarm such as the Delta AlertMaxx2 and power back up system such as Delta PowerMaxx in case of mains power failure. Again reducing the risk of potential flooding to the basement.

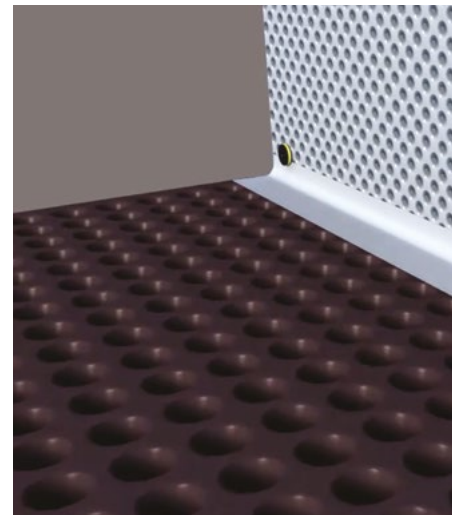

# DELTA PUMPS

## GROUND WATER/SURFACE WATER SUBMERSIBLE PUMPS

Ground water should be managed in a safe, economic and robust fashion. Delta's extensive range of sumps are suitable for ground water management.

Our Ground Water/Surface Water Submersible Pumps and Pump Stations are capable of pumping water containing up to 10mm of solids. They are suitable for installation at the initial building stage or retro fitting to an existing structure.

Ground water and Foul water should NEVER be mixed into the same chamber as this can lead to odours and clogging.

Our range consists of an HDPE tank, site cover, internal pipe work and submersible pump(s). Our chambers are spun bonded in one unit manufactured from ISO 13/14 grade to withstand ground water pressure that may be exerted on the chamber.



## KEY FEATURES

- Single or dual pump
- Suitable for use with the MaxxFamily product range
- Ready for immediate and simple installation
- Suitable for Flood Resilience
- Suitable for new, existing and retrofit basement projects
- Ability to easily deal with aggressive ground water conditions
- Service Plans available through our pump partners if required

## APPLICATIONS

- Residential Buildings
- Commercial Buildings
- Retail Units and Warehouses
- Leisure Facilities
- Archives/Libraries/Vaults
- Hospitals
- Schools
- Underground Rail Stations and Tunnelling
- Underground Car Parking areas
- Listed Buildings
- Heritage Buildings
- Insulated Formwork Construction (ICF)





# DUAL V3 SUMP

Pumping applications are invariably demanding – typically operating in unsympathetic, arduous or extreme environments, where quality matters. The Dual V3 packaged pump station has been specifically designed to work in harmony with the Delta Cavity Drainage System to collect Ground Water via a perimeter channel or 110mm pipe (129 Detail). Manufactured from superior High Density Polyethylene (HDPE) this package pump station is able to withstand hydrostatic forces. The Dual V3 pump offers unrivalled capabilities. The Dual V3 sump offers versatility of collecting water from external light-wells.



The Dual V3 pump station package includes chamber, all internal pipe work and two powerful V3 pumps.

The Dual V3 pump station is suitable for collecting Ground Water from a 150m<sup>2</sup> basements and Surface Water from a 12m<sup>2</sup> light well.

## SPECIFICATION

NBS specification R18 (Clause 310) Pumping Stations and Pressure Pipelines.

BS 8102:2009 Type C Drained Protection.

Pump Model	V3
Voltage	230V
KW Rating (P1 / P2)	0.43 / 0.18kW
Full Load Current	1.9A
Fuse Spur Rating	13A
Typical Duty	2.0l/s @ 3.5m
Power Phase	Single
Weight	5.64kg

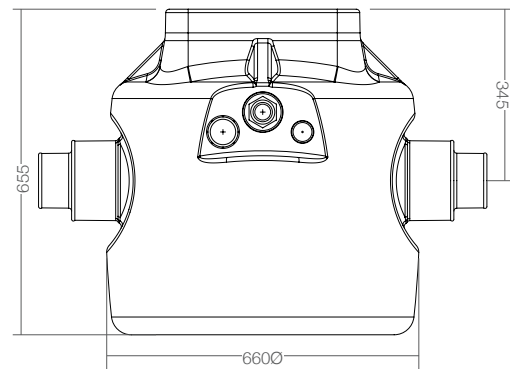
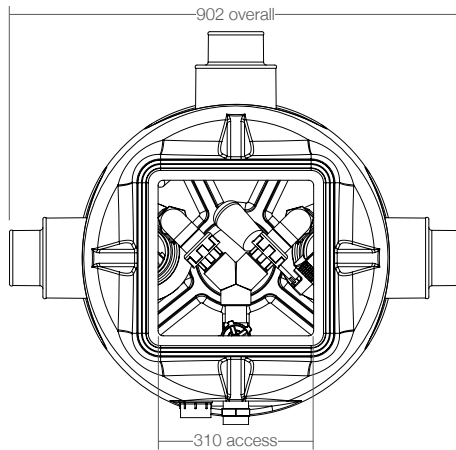

Chamber	Dual V3
Chamber Material	High Density Polyethylene
Volume Below Inlets	87L
Volume Total	217L
Fixed Inlets	3 x 110 / 160mm
Cable Duct	50mm
Discharge Connection	1.25" / 32mm BSP Class C
Discharge Pipework	1.25" / 32mm BSP Class C
Internal Pipework	1.25" / 32mm BSP Class C
Cable Duct Pipework	2" / 50mm White Waste Pipe

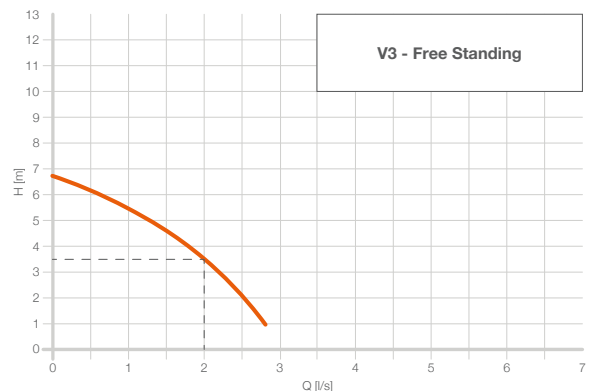

# DUAL V3.1 SUMP

We use the most advanced design to evaluate, refine and manufacture the best pump solutions available, the Dual V3.1 packaged pump station works in tranquillity with the Delta Cavity Drainage System to collect ground water via a perimeter channel or 110mm pipe (129 Detail). Manufactured from exclusive High Density Polyethylene (HDPE) this package pump station has been designed to withstand the highest hydrostatic stress. The Dual V3.1 pump is a dry run pump offering reassurance in its capabilities. The Dual V3.1 is suitable for collecting grey water waste from showers and hand basins.



The Dual V3.1 pump station package includes chamber, all internal pipe work and two powerful V3 pumps.

The Dual V3.1 pump is ideal for smaller retrofit basements or where space is limited.

## SPECIFICATION

NBS specification R18  
(Clause 310)  
Pumping Stations and Pressure Pipelines.

BS 8102:2009 Type C Drained Protection.

Pump Model	V3
Voltage	230V
KW Rating (P1 / P2)	0.43 / 0.18kW
Full Load Current	1.9A
Fuse Spur Rating	13A
Typical Duty	2.0/s @ 3.5m
Power Phase	Single
Weight	5.64kg

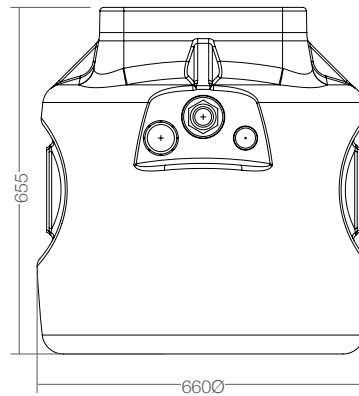
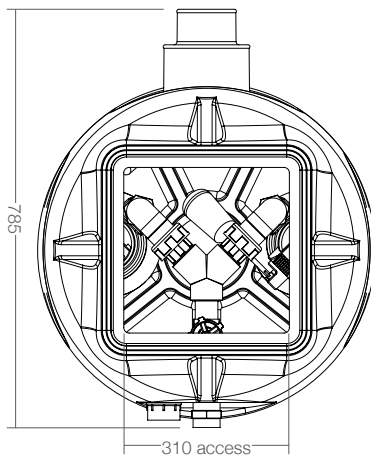

Chamber	Dual V3.1
Chamber Material	High Density Polyethylene
Volume Below Inlets	87L
Volume Total	217L
Fixed Inlets	1 x 110 / 160mm
Cable Duct	50mm
Discharge Connection	1.25" / 32mm BSP Class C
Discharge Pipework	1.25" / 32mm BSP Class C
Internal Pipework	1.25" / 32mm BSP Class C
Cable Duct Pipework	2" / 50mm White Waste Pipe

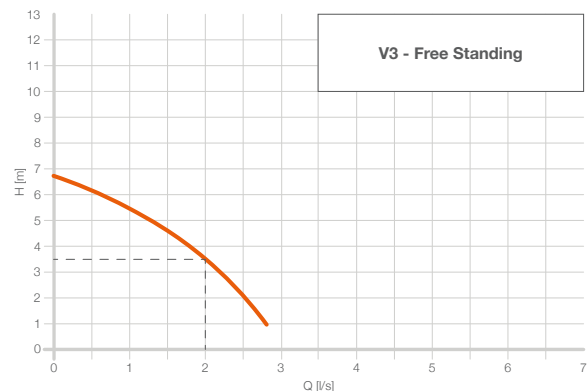

# DUAL V4 SUMP

Delta's robust and distinguished package pumps are capable of diverse applications where quality matters. Using advanced pump design techniques our packaged systems are designed and manufactured here in the United Kingdom. The Dual V4 packaged pump station has been specifically designed to work in unity with the Delta Cavity Drainage System to collect ground water via a perimeter channel or 110mm pipe (129 Detail). The Dual V4 offers a higher discharge head to the V3 range and is suitable for double and triple depth basements. Manufactured from High Density Polyethylene (HDPE) this package pump station has been designed to withstand the strongest hydrostatic stress.



The Dual V4 pump station package includes chamber, all internal pipe work and two powerful V4 pumps.

The Dual V4 pump station is suitable to collect ground water from a 150m<sup>2</sup> basement that requires a head height over 3m. The Dual V4 is capable of pumping 12m<sup>2</sup> of surface area in addition to ground water.

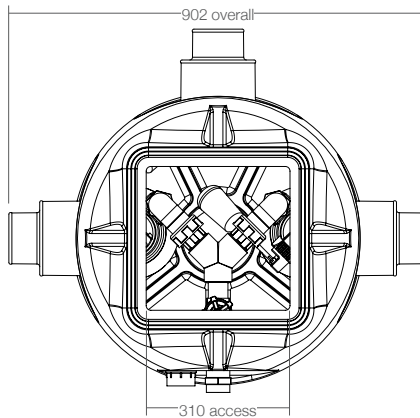

## SPECIFICATION

NBS specification R18  
(Clause 310)  
Pumping Stations and Pressure  
Pipelines.

BS 8102:2009 Type C Drained  
Protection.

Pump Model	V4
Voltage	230V
KW Rating (P1 / P2)	0.75 / 0.36kW
Full Load Current	4.0A
Fuse Spur Rating	13A
Typical Duty	2.0l/s @ 7m
Power Phase	Single
Weight	6.7kg

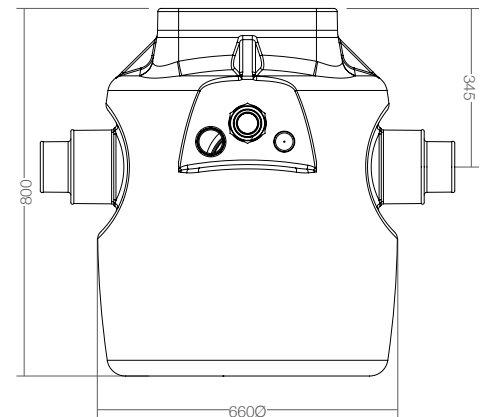

Chamber	Dual V4
Chamber Material	High Density Polyethylene
Volume Below Inlets	137L
Volume Total	273L
Fixed Inlets	3 x 110 / 160mm
Cable Duct	50mm
Discharge Connection	2" / 50mm BSP Class C
Discharge Pipework	2" / 50mm BSP Class C
Internal Pipework	1.25" / 32mm BSP Class C
Cable Duct Pipework	2" / 50mm White Waste Pipe
Vent Pipework	2" / 50mm White Waste Pipe

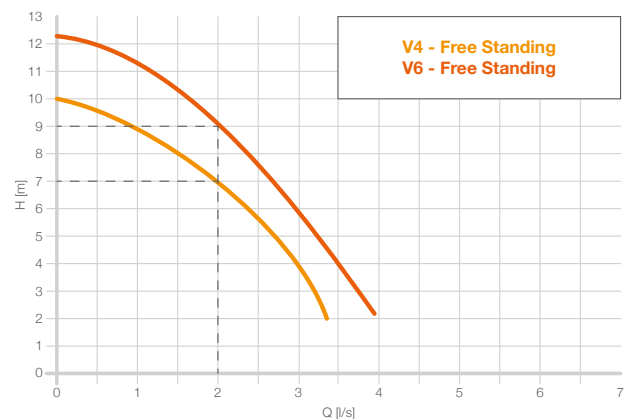

# DUAL V6 SUMP

Manufactured in the United Kingdom to the highest of quality, our V6 pump station can meet the requirements of the toughest environment. The Dual V6 has the capabilities to discharge water ingress from surface areas over 150m<sup>2</sup> or basements that require a head height above 3m. The Dual V6 packaged pump station has been distinctively designed to work in unity with the Delta Cavity Drainage System to collect ground water via a perimeter channel or 110mm pipe (129 Detail). Manufactured from High Density Polyethylene (HDPE) this package pump station can effortlessly withstand the strongest hydrostatic stress.

The Dual V6 pump station package includes chamber, all internal pipe work and two powerful V6 pumps.



## SPECIFICATION

NBS specification R18  
(Clause 310)  
Pumping Stations and Pressure  
Pipelines.

BS 8102:2009 Type C Drained  
Protection.

Pump Model	V6
Voltage	230V
KW Rating (P1 / P2)	0.75 / 0.36kW
Full Load Current	4.0A
Fuse Spur Rating	13A
Typical Duty	2.0l/s @ 7m
Power Phase	Single
Weight	6.7kg

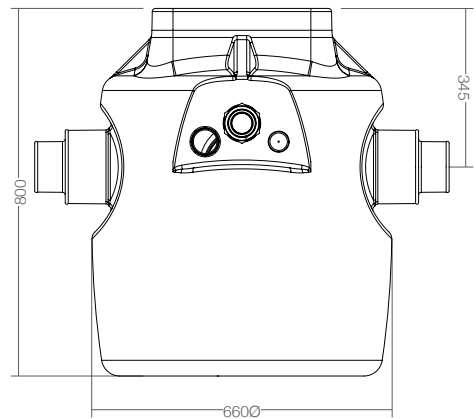
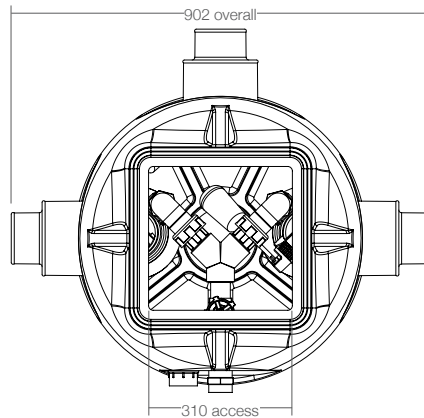

Chamber	Dual V6
Chamber Material	High Density Polyethylene
Volume Below Inlets	137L
Volume Total	273L
Fixed Inlets	3 x 110 / 160mm
Cable Duct	50mm
Discharge Connection	2" / 50mm BSP Class C
Discharge Pipework	2" / 50mm BSP Class C
Internal Pipework	1.25" / 32mm BSP Class C
Cable Duct Pipework	2" / 50mm White Waste Pipe
Vent Pipework	2" / 50mm White Waste Pipe

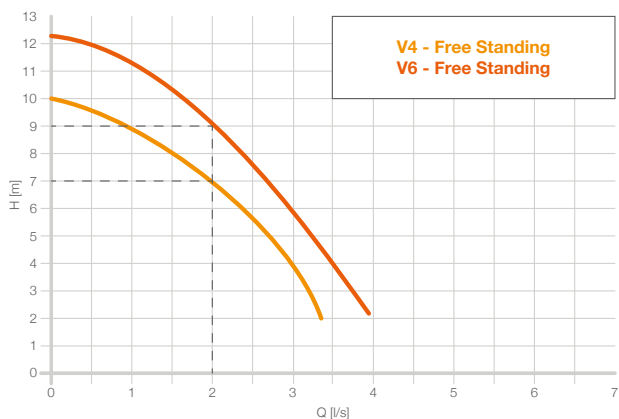

# FOUL WATER SUBMERSIBLE PUMPS

Our Foul range is suitable for Foul Water Management. Our Foul Water Submersible Pumps and Pump Stations are capable of pumping water containing up to 60mm of solids using vortex technology.

Our Foul range is suitable for installation at the initial building stage or retro fitting into an existing structure.

Foul water and ground water should NEVER be mixed into the same chamber as this can lead to odours and clogging.

The Foul range consists of a HDPE tank, site cover, internal pipework and submersible pump.

For appropriate Foul water system specifications to suit your project requirements contact:

Delta Membrane Systems Ltd,  
Technical Department  
01992 523523  
info@deltamembranes.com



## KEY FEATURES

- Single or dual pump
- Bespoke Options
- Suitable for use with the MaxxFamily product range
- Ready for immediate and simple installation
- Suitable for new, existing and retrofit basement projects
- Service Plans available

## APPLICATIONS

- Residential Buildings
- Commercial Buildings
- Retail Units and Warehouses
- Leisure Facilities
- Archives/Libraries/Vaults
- Hospitals
- Schools
- Underground Rail Stations and Tunnelling
- Underground Car Parking areas
- Listed Buildings
- Heritage Buildings
- Insulated Formwork Construction (ICF)

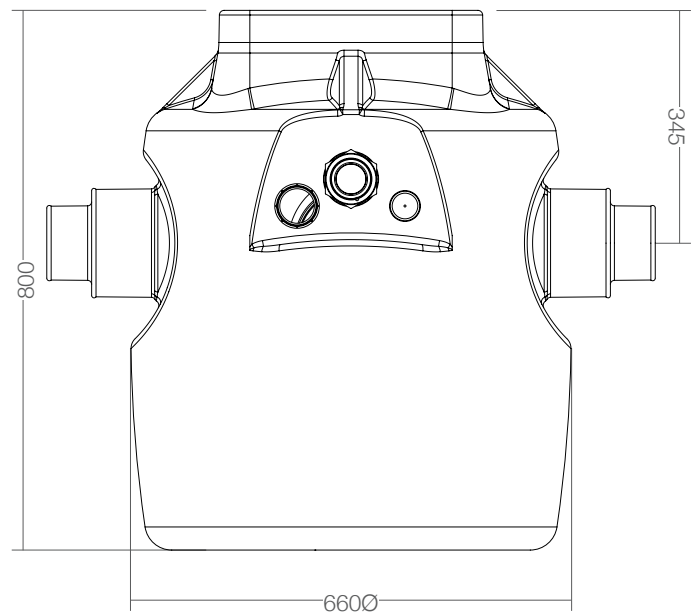
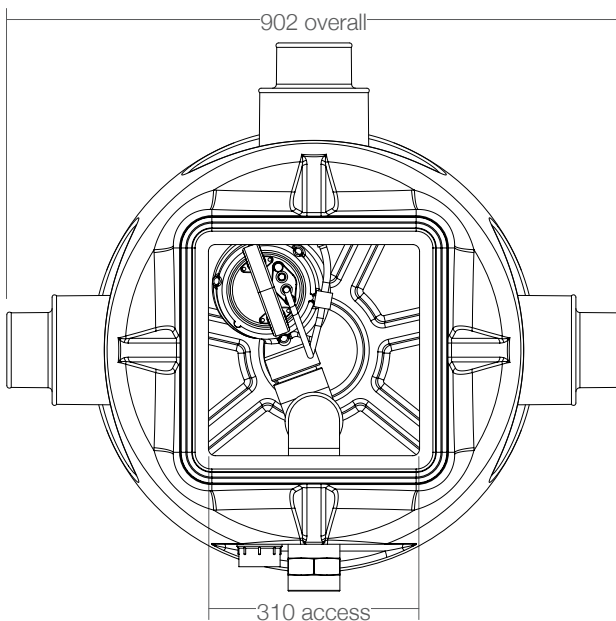

# FOUL V3 PUMP STATION

Superior design, precision manufacturing and high quality assurance has made Delta a trusted name for package pump stations, our impressive history for reliability; durability and customer service are unrivalled. Our Foul V3 sump has been designed to collect foul water and/or grey water from basements and ground floor extensions. The Foul V3 package pump station is not suitable for collecting ground water from a Cavity Drainage System. Manufactured from first-rate High Density Polyethylene (HDPE) this package pump station has been designed to withstand the strongest hydrostatic stress.

The Foul V3 pump station package includes chamber, all internal pipe work and a powerful D10 foul vortex pump.

Manufactured in the United Kingdom to the highest of quality. Our bespoke range is produced to any size/requirements. Our bespoke range is suitable for ground, surface and foul water.



## SPECIFICATION

NBS specification R18  
(Clause 310)  
Pumping Stations and Pressure  
Pipelines.

BS 8102:2009 Type C Drained  
Protection.

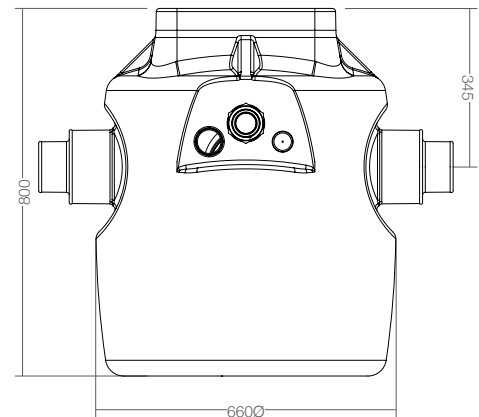
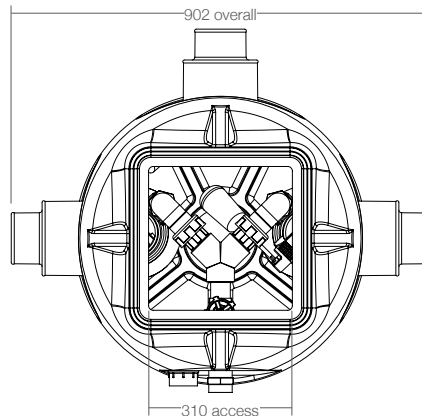

Chamber	Foul V3
Chamber Material	High Density Polyethylene
Volume Below Inlets	137L
Volume Total	273L
Fixed Inlets	3 x 110 / 160mm
Cable Duct	50mm
Discharge Connection	2" / 50mm BSP Class C
Discharge Pipework	2" / 50mm BSP Class C
Internal Pipework	2" / 50mm BSP Class C
Cable Duct Pipework	2" / 50mm White Waste Pipe
Vent Pipework	2" / 50mm White Waste Pipe

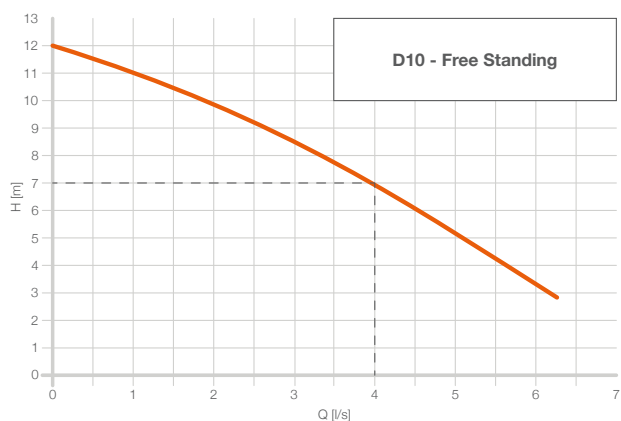

# ALARMS, MONITORING AND BATTERY BACK-UP

## ALARMS AND MONITORING SYSTEMS

High level water alarms or high level alarms are used to provide a warning of pump failure. Should the water level rise to a high point within the pump chamber an alarm will sound to alert the property owner.

### ALERTMAXX2 – HIGH LEVEL ALARM AND MONITORING SYSTEM

The AlertMaxx2 is an intelligent high water level alarm and monitoring system which can be connected to your sump pump and Wi-Fi system. The AlertMaxx2 will monitor the pump stations performance improving efficiency and reduce energy consumption. The AlertMaxx2 performs regular health checks on the pump system ensuring pumps are running efficiently using state of the art sensors which measure 10 different pump parameters and variables and utilises the data provided by the pumps themselves.

Think of the AlertMaxx2 as having a virtual pump service engineer ensuring your pump station is working to its optimum performance, monitoring, recording and alerting you and other stakeholders to any potential issues before they occur.

The MaxxFamily is a range of products specifically designed for the submersible pump industry.

The MaxxFamily product range offers optimum functionality, maximum efficiency and ease of installation.

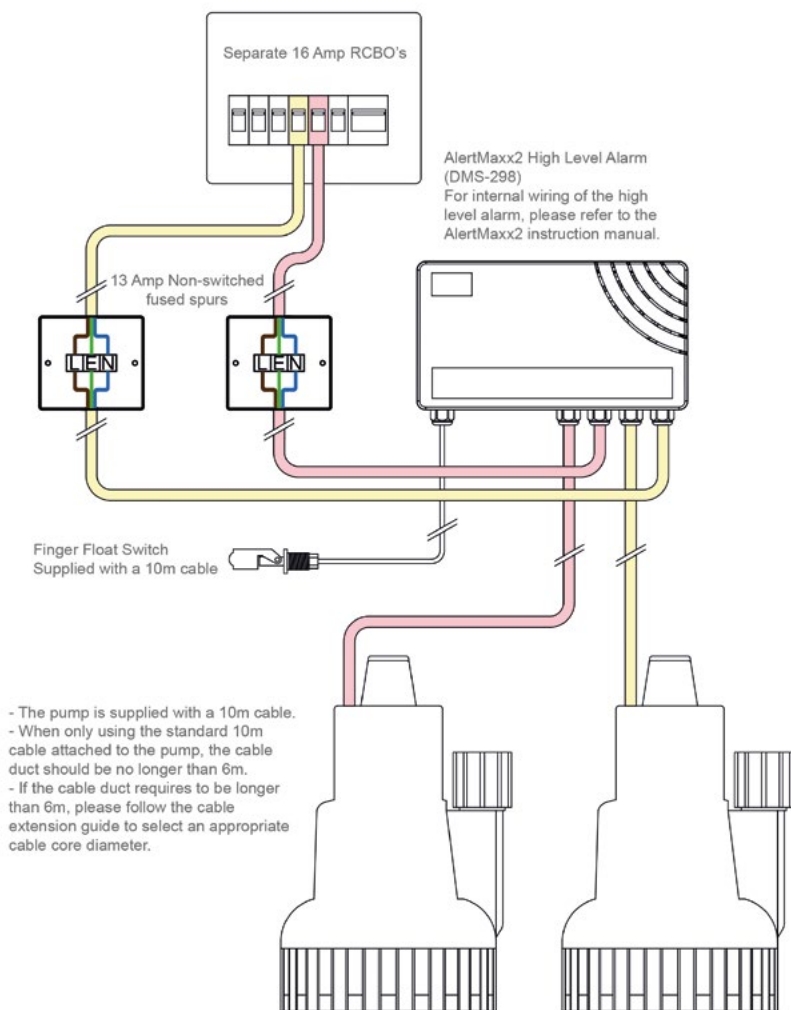

- The pump is supplied with a 10m cable.
- When only using the standard 10m cable attached to the pump, the cable duct should be no longer than 6m.
- If the cable duct requires to be longer than 6m, please follow the cable extension guide to select an appropriate cable core diameter.

The electrical installation must comply with the requirements of BS 7671:2008 'Requirements for Electrical Installations' incorporating amendment 3:2015



# BATTERY BACK-UP

## POWERMAXX

- The PowerMaxx has been specifically designed for sump pump applications.
- During power failure the PowerMaxx will automatically run the sump pump system, ensuring your structure is kept dry and the pumps running.
- The PowerMaxx is capable of running both primary and secondary pumps.
- The PowerMaxx is able to run 1 x V3 ground water pump without mains power for up to 4 days (depending on number of cycles/hr).
- The PowerMaxx is able to sit in standby mode for 10 days.
- The PowerMaxx is virtually inaudible.
- Internal trickle charger keeps the unit fully charged so ready whenever there is power failure.
- The PowerMaxx will automatically recharge when mains power returns.
- Easy Installation.
- The PowerMaxx is free standing and can be installed in any dry ventilated area.
- The PowerMaxx unit is fitted in a series between the spur and the pump; no additional electrical spurs are required.
- The PowerMaxx can operate as a stand-alone unit or can be used in conjunction with AlertMaxx2.
- It can also be used as a direct replacement for previous versions.

With a battery backup, peace of mind is a standard. Our reliable Battery Backups will keep your pumps running during power failure, ensuring your property is kept dry; a flooded basement can result in costly repairs. Our Battery Backups are leading the industry in performance, hours of additional protection are offered to your property from water damage in the event of power failure.

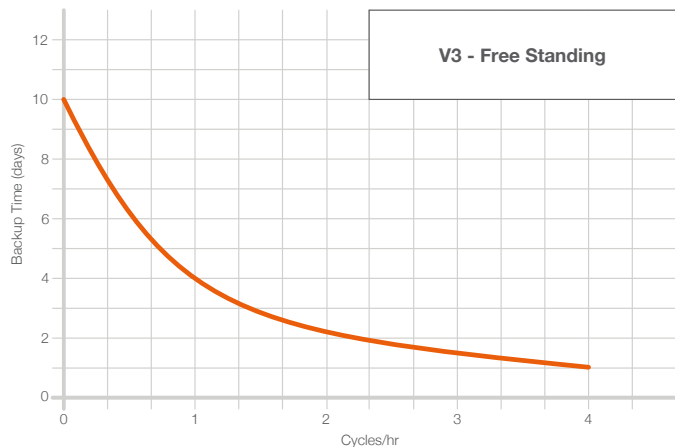

	POWERMAXX
Size (without cable glands)	155mm x 425mm x 300mm
Weight (without batteries installed)	6.5kg
Weight (with batteries installed)	19.5kg
Mains supply	200-250V AC (50Hz)
Internal batteries	24V – 5 x 22 Ah Total = 100 Ah
Power (standby)	<3W
Peak Power Handling	600W P1
Power (charging)	55W
Visual display	Red, Blue, Green LED
Operating temperature	5-35°C
Approximate installation time	30 minutes
Warranty	2 years
Pump Type	V3



## HI-POWERMAXX

- The Hi-PowerMaxx provides battery backup for larger pumps such as the V4, V6, Foul and Bespoke.
- The Hi-PowerMaxx provides standby mode for 50 days.
- The Hi-PowerMaxx is virtually inaudible.
- The Hi-PowerMaxx is capable of running both primary and secondary pumps.
- The Hi-PowerMaxx provides 13 days pump time based on 1 cycle/hr of a V6 pump.
- An electric charger keeps the Hi-PowerMaxx battery-backup fully charged so it'll be ready at any time.
- Internal trickle charger keeps the unit fully charged so ready whenever there is power failure.
- The Hi-PowerMaxx will automatically recharge when mains power returns.
- Easy Installation.
- The Hi-PowerMaxx is free standing and can be installed in any dry ventilated area.
- The Hi-PowerMaxx unit is fitted in a series between the spur and the pump; no additional electrical spurs are required.
- The Hi-PowerMaxx is part of the MaxxConnect family and can operate as a stand-alone unit or can be used in conjunction with the AlertMaxx2.
- The Hi-PowerMaxx can also be used as a direct replacement for previous versions.

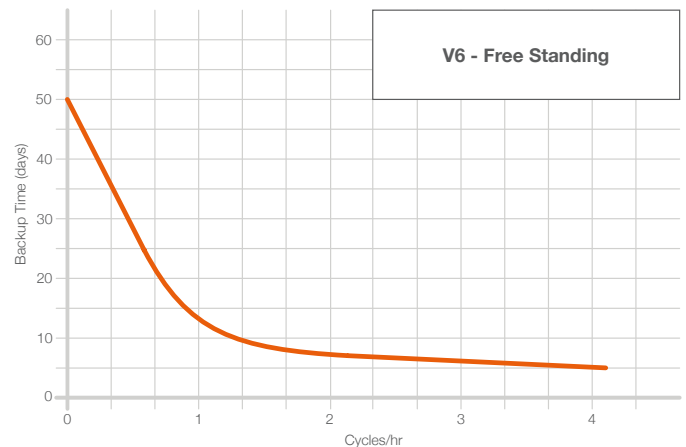

	HI-POWERMAXX
Size (without cable glands)	475mm x 425mm x 300mm
Weight (without batteries installed)	15.5kg
Weight (with batteries installed)	80.5kg
Mains supply	200-250V AC (50Hz)
Internal batteries	24V – 5 x 22 Ah Total = 100 Ah
Power (standby)	<3W
Peak Power Handling	2000W P1
Power (charging)	55W
Visual display	Red, Blue, Green LED
Operating temperature	5-35°C
Approximate installation time	30 minutes
Warranty	2 years
Pump Type	V4/V6/D10

# SERVICING PLANS & COMMISSIONING

## SERVICING PLANS

Sump pumps must be maintained. We recommend a qualified engineer examines and services equipment every year. Pumps running frequently due to higher water table, water drainage, or weather conditions should be examined more frequently, we recommend every 6 months. Sump pumps, being mechanical devices, may fail if not maintained which could lead to a flooded basement and costly repairs.

Regular servicing of sump pumps will increase efficiency and extend the life of the pump. All Delta Membrane pump systems can be maintained by our partners, Packaged Pump Systems (PPS) or installing contractor.

## COMMISSIONING

All sump pumps require commissioning. Commissioning provides peace of mind, knowing that the system is installed correctly and in compliance with warranty conditions.

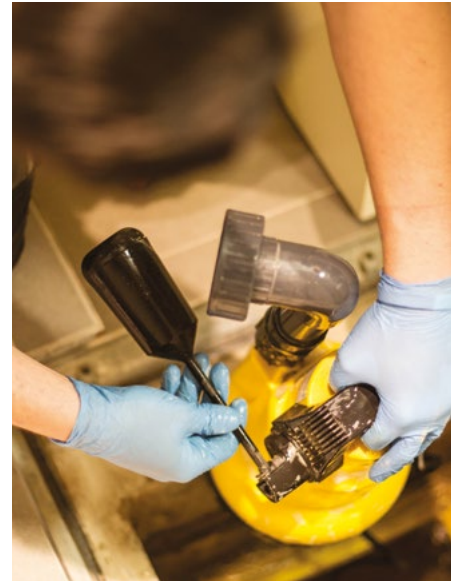

# GUARANTEES



## AVAILABLE FROM DELTA MEMBRANES

- Installation Guides
- Technical Guidance Literature
- Product Data sheets
- BBA Approval/Third Party Accreditation
- BIM Objects
- CAD Drawings
- CE Marking Certificates
- Delta Training Courses
- RIBA Approved CPD Seminars
- Case Studies
- Design Assistance

## GUARANTEES

Delta Membrane Systems Limited offer a 30 year Product Guarantee on membranes, seals and fixings when a Delta Cavity Drain System has been installed by a Delta Registered Installer.

## STRUCTURAL WARRANTY PROVIDERS

Delta products are well known and accepted by the NHBC, Premier Guarantee and LABC (to name but a few) and follow the guidance required to ensure a robust design is achieved. Delta Membrane Systems Limited assisted with the writing of the NHBC new Chapter 5.4 and have CSSW qualified staff on hand to assist in all aspects of the design process. A Waterproofing Design Specialist should carry appropriate Professional Indemnity Insurance to cover the design.

## FLOOD TESTING

A requirement for any project before installing a Cavity Drain System below ground is to Flood Test the structure. This is a huge benefit with a Type C form of waterproofing system.

## ADDITIONAL INFORMATION

For additional information or assistance, please contact:

Delta Membrane Systems Ltd.  
Tel: 01992 523523  
Email: [info@deltamembranes.com](mailto:info@deltamembranes.com)



All Technical Values are approximate and slight variations may occur.

Head Office:

Delta House, Merlin Way, North Weald, Epping, Essex, CM16 6HR

01992 523 523 | [info@deltamembranes.com](mailto:info@deltamembranes.com) | [www.deltamembranes.com](http://www.deltamembranes.com)

DCDB/1/2018V2