

ACO KerbDrain®

Combined kerb and drainage system
Interactive digital brochure



This brochure has been specifically prepared to be viewed digitally.
Please consider the environment and do not print this brochure unless you really need to.

Introduction to ACO KerbDrain®

The ACO KerbDrain® combined kerb and drainage system provides versatile and efficient linear drainage for motorways, trunk roads, urban infrastructure and landscaping projects.

What is ACO KerbDrain®?

ACO KerbDrain® is a one-piece combined kerb and drainage system specifically designed and developed to form an integral part of any modern, sustainable surface water management solution. The system is suitable for a wide range of applications including major and minor highways, car parks, and commercial and urban landscaping.

ACO KerbDrain® provides many versatile solutions for both SuDS schemes and traditional drainage systems.

Engineers and designers are able to combine the benefits of both “hard” and “soft” SuDS to achieve the key elements of quality, quantity and amenity.

Since its launch in the late 1990's, over 750,000m of ACO KerbDrain® has been supplied to a wide variety of projects in both the UK and mainland Europe. In recognition of ACO KerbDrain's ground breaking one-piece design, the system was awarded the Queen's Award for Enterprise: Innovation in 2001.

ACO KerbDrain® has a range of units to match HB1, HB2 and 45° splayed profiles, and a selection of depths and lengths to meet the hydraulic and performance requirements of many highway or drainage schemes.

The system also benefits from an extensive range of complementary and problem solving components including perforated and flush centre stones, drop kerbs, radius and mitred units, internal angles, quadrants, and bus stop units.

The ACO KerbDrain® system

The main 1m and 0.5m units form the core of the range and are available in either Half Battered (HB) or Splayed (SP) profiles. Each unit has two surface water drainage inlets per 0.5m, which are designed to prevent blockages by silt and debris, ensuring maximum drainage efficiency of carriageways and paved surfaces.

ACO KerbDrain® units are available in 255mm, 280mm, 305mm, 380mm, 405mm and 480mm depths, which enable engineers and designers to optimise scheme hydraulics for efficient and economical drainage.

When compared to traditional kerb and point gully drainage, ACO KerbDrain® delivers a lower cost option. It also removes problems associated with incorrectly sited point gullies by ensuring all surface water runoff is safely removed over the entire length of the installation.

Maintenance of ACO KerbDrain® is provided for by lockable rodding access points and gully units which allow the system to be simply and efficiently cleaned by standard jetting equipment.

Installation benefits

The one-piece construction of ACO KerbDrain® and the lightweight properties of Vienite® ensure the system is quick and easy to install, even when a fully watertight installation is required. Whether you are installing products manually or mechanically to meet HSE guidelines for kerb laying, ACO KerbDrain® provides the optimum solution.



ACO Hydraulic Design Software

Register online for our free, secure online design software to create ACO KerbDrain® drainage designs:

- ▶ All designs are securely stored and easily accessed online
- ▶ Data always up-to-date
- ▶ Proven calculation methodology - more accurate and efficient designs
- ▶ Flexible catchment design
- ▶ Integrated rainfall data
- ▶ Automated product optimisation
- ▶ PDF summary documents



Register Now - It's Free
www.acodesign.co.uk

Why choose ACO KerbDrain®

- ▶ Impact resistance 50% higher than OPC kerb units
- ▶ Manufactured from sustainable material
- ▶ Certified for all highways applications
- ▶ Full range of problem solving components for all sizes
- ▶ Capacity choices optimise hydraulic performance
- ▶ Award winning one-piece design
- ▶ SuDS compliant
- ▶ Simple watertight installations
- ▶ Safe manual and mechanical handling
- ▶ High daily installation rate

Made from sustainable materials

All ACO KerbDrain® products are manufactured from Vienite®, ACO's new high strength sustainable material that meets environmental and sustainability targets for construction products.

Four times stronger than traditional concrete, Vienite® utilises high levels of post-consumer recycled waste, but unlike some recycled materials does not compromise strength or long-term performance. For more information on Vienite®, [click here](#).



Proven performance

ACO KerbDrain® meets the highest levels of certification, performance and quality assurance for combined kerb drainage systems. It is fully certified to Load Class D 400 BS EN 1433:2002 and CE marked, and is 50% more impact resistant than traditional OPC kerb units.

ACO KerbDrain® carries the BSI Kitemark, independently assuring performance and quality and making the system fully compliant with the specification for Highways Works Clause 516 and all Highways Agency product and certification requirements.



ACO KERBDRAIN® FEATURES OVERVIEW

Kerb profiles

ACO KerbDrain® units are available in half battered (HB) or splayed (SP) profiles to BS EN 1340:2003.



Half battered units (HB)



Splayed units (SP)

DF hole for draining porous asphalt or providing temporary drainage of subsurface during installation

Sealant groove for simple watertight installations

Made from sustainable materials
Thermally stable, chemically resistant, environmentally friendly product manufactured from Vienite® sustainable material. For more information on Vienite® [click here](#).



Choice of depths
Available in 255mm, 280mm, 305mm, 380mm, 405mm and 480mm depths

Drainage inlets designed to resist debris blockage

50% higher impact resistance than traditional OPC kerbs

Load Class D 400
ACO KerbDrain® is fully certified to Load Class D 400 BS EN 1433:2002 and CE marked

Installation benefits
Kerb units available in 1000mm and 500mm lengths

External surfaces anchor channel securely into concrete surround to prevent displacement

Highways Agency approved
Complies with IAN 117/08, Clause 516 SHW and is Kitemarked to BS EN 1433:2002 for highway use.



BS EN 1433
KM 538856

Problem solving components

Each size of ACO KerbDrain® has its own set of components to complement any highway drainage design. A list of the main components available is shown below, however full details of the parts available can be found in the relevant sections.



Centre stones



Access units



Drop kerb assemblies



Inlet/outlet end caps

LOAD CLASSES

A 15
Pedestrian, cycleways and domestic drives.

B 125
Pedestrian precincts, light vehicles, private car parks and drives.

C 250
Parking areas, service stations (cars) and slow-moving light commercial vehicles.

D 400
Public highways, parking areas for all types of vehicles, distribution yards

Problem solving with ACO KerbDrain®

In addition to providing efficient drainage of carriageways and paved surfaces, ACO KerbDrain® can be used to solve many drainage problems created within the modern built environment.

Some examples of how ACO KerbDrain® is successfully used by engineers and designers are shown here.

For more ACO Water Management case studies [click here](#).



If you need help with specification, design or installation, or just wish to learn more about this and other Surface Water Management products from ACO, contact our free, no obligation ACO Water Management Design Services Team who can provide advice and dedicated design support for your project – 01462 816666 or visit www.aco.co.uk.

Pedestrian crossings

• PROBLEM:

Carriageway and footpath cross-falls create a significant risk of standing water at pedestrian crossings.



• SOLUTION:

- ACO KerbDrain® HB255 and HB305 offer products such as drop kerbs and flush drainable centre stones to enable efficient and proper drainage of these areas.
- The photograph shows ACO KerbDrain® HB305 flush drainable centre stones being used to provide drainage and compliance to the DfT 'Guidance on the use of tactile paving surfaces' at a pedestrian crossing.

Roundabouts

• PROBLEM:

Complex carriageway cross-falls created in the construction of roundabouts can make it extremely difficult to site traditional point gullies correctly to capture standing water. Unless the water is effectively drained, ponding at roundabouts can be particularly hazardous to motorists and cyclists.



• SOLUTION:

- ACO KerbDrain® HB305 and HB480 ranges have dedicated radius and mitred units for roundabout construction, which can be installed on radii from 6m to 25m. External and internal mitre units are available to ensure efficient drainage of the curved perimeters found at roundabouts. ACO KerbDrain® units have multiple surface water inlets providing continuous linear drainage of the entire carriageway.
- The photograph shows ACO KerbDrain® HB480 external mitre units being used to provide drainage of a roundabout (HB305 mitre units also available).

T-Junctions

• PROBLEM:

Where side roads adjoin the main carriageway, flow of surface water along the gutter can be impeded or prevented leading to standing water and drainage issues. Surface water runoff from side roads entering the main carriageway can also be a hazard to road users.



• SOLUTION:

- The ACO KerbDrain® range provides all the necessary products to effectively drain the road junction, from mitred and radius units for the corners to dedicated junction channels and end caps that provide continuous and effective interception and drainage of surface water flows across the junction.
- The photograph shows ACO KerbDrain® HB480 external mitre units and HB480 junction channel units being used to provide drainage at a T junction.

Traffic calming and raised pedestrian crossings

• PROBLEM:

Raised carriageway surfaces forming traffic calming measures or pedestrian crossings can impede or prevent the flow of surface water along the gutter.

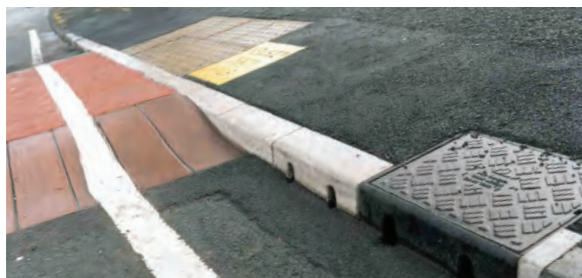

• SOLUTION:

- ACO KerbDrain® units without front drainage inlets are available and are referred to as blind units. These blind units prevent construction material entering the ACO KerbDrain® system and provide continuous drainage through the raised carriageway surface. Effective drainage of the carriageway is maintained and the risk of ponding is eliminated.
- The photograph shows ACO KerbDrain® HB305 blind units being used to provide drainage at a raised traffic calming measure (blind units also available in HB405 and HB480 ranges).

Bus stops

• PROBLEM:

Carriageway cross-falls can lead to standing water and drainage issues at bus stops causing discomfort and inconvenience to pedestrians.



• SOLUTION:

- ACO KerbDrain® HB480 offers dedicated transition and bus stop elements which raise the kerb upstand to increase pedestrian safety and improve access to public transport vehicles. ACO bus stop kerbs link to standard ACO KerbDrain® HB480 units and provide continuous drainage of the carriageway and bus stop.
- The photograph shows ACO KerbDrain® HB480 bus stop kerbs and transition kerbs being used to provide drainage at a bus stop. ACO KerbDrain® HB305 bus stop kerbs and transition kerbs are also available upon request.

Tunnels

• PROBLEM:

Installation depths within tunnel construction can be restricted. Yet in the event that high volumes of hazardous liquid are discharged onto the road surface, such as a tanker spillage, rapid collection and containment is paramount for the safety of road users and the environment.



• SOLUTION:

- The compact nature of ACO KerbDrain® combined with its high hydraulic capacity makes it ideal for use within the confines of a tunnel. Liquid-tight installations can quickly and efficiently be achieved to ensure that any hazardous liquids entering the ACO KerbDrain® system are contained prior to safe removal.
- The photograph shows ACO KerbDrain® HB480 kerb units being used to provide drainage of a tunnel.

SuDS

• PROBLEM:

Providing a Sustainable Drainage System (SuDS) for new and re-developments can present engineers and designers with significant challenges to deal with the quality, quantity and amenity of the surface water runoff. Restrictions of space, local topography or site specific conditions such as high natural water tables can mean that "Soft SuDS" solutions alone are unsuitable.



• SOLUTION:

- ACO KerbDrain® can be successfully used in SuDS schemes by allowing engineers and designers to combine the benefits of "hard SuDS" such as combined kerb drainage with traditional "soft SuDS" solutions such as swales, ponds and wetlands
- The photograph shows ACO KerbDrain® HB305 kerb and access units being used to provide drainage of a highway in conjunction with a swale.

ACO KerbDrain® project case studies

The many benefits of ACO KerbDrain® have, since its launch, helped architects, engineers and contractors realise some of the country's most ambitious, groundbreaking and high profile projects.

In differing applications with widely varying objectives, the ACO Water Management Design Services Team has played a key partnering role, ensuring each finished system not only met those objectives but added wider value.

This page demonstrate how ACO KerbDrain® has provided efficient and cost effective combined kerb drainage to a diverse range of applications.

 For more ACO Water Management case studies visit www.aco.co.uk.

Modification service

Drain Specials is a section of the business which is able to adapt existing standard ACO drainage products to suit the specific requirements of a project or customer. [Click here](#) for more information.

Project requirement: Design versatility

Project name: [Connecting Derby, Inner Ring Road](#)

Client & design engineer:
Derby City Council

Contractor:
BAM Nuttall



At £36 million, Connecting Derby is one of the most ambitious projects ever undertaken in the city. With its objective to improve transport links in and around the city, designers focused on developing a value engineered solution that considered every aspect of installation, operation and maintenance. The versatility of the ACO KerbDrain® range meant just one system could be used for all the individual highway applications - bus stops, roundabouts, pedestrian crossings etc – ensuring consistent high product quality, optimum drainage performance and minimal ongoing maintenance costs as only one product range needs to be held in the city's stock yards.

[Download the full case study](#) 

Project requirement: Innovative SuDS

Project name: [Henry Box housing estate, Oxfordshire](#)

Client:
Sovereign Housing Association

Design engineer:
Oxfordshire County Council

Contractor:
Atkins

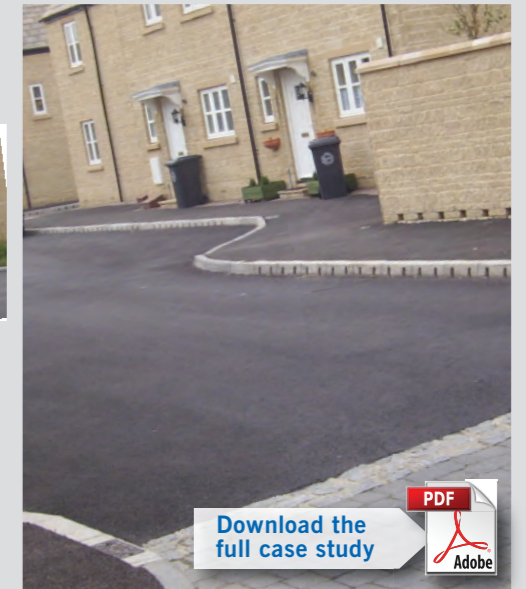

Early collaboration between Oxfordshire County Council and ACO proved decisive in developing a successful sustainable drainage system that has allowed a housing estate to be developed on a challenging, flood-prone site. By exploiting ACO KerbDrain's inherent high storage capacity and its flexible installation detail, an innovative integrated drainage system has been created which removes surface water from all road surfaces and roofs across the development. Proven under the most extreme storm conditions of recent years, the system not only protects the houses from flooding but also prevents local water courses from overflowing.

[Download the full case study](#) 

Project requirement: Protecting the environment

Project name: [Hindhead Tunnel, Surrey](#)

Client:
Highways Agency

Design engineer:
Mott MacDonald

Contractor:
Balfour Beatty Civil Engineering



The UK's longest in shore road tunnel on the A3 at Hindhead has been constructed to protect and preserve the environmentally sensitive Devil's Punch Bowl. In line with the project's demanding sustainability and performance targets, ACO KerbDrain® was selected to provide the drainage for each bore of the 1.8km tunnel. In addition to the environmental benefits of its construction material, Vienite®, ACO KerbDrain's one-piece design meant it could be easily sealed during installation. Sealing prevents any potentially hazardous liquids leaking into the surrounding soil and, by doing it faster, speeds installation, lowering total carbon used.

[Download the full case study](#) 

Project requirement: Bespoke solutions

Project name: [T5, London Heathrow Airport](#)

Client:
BAA Airports Ltd



Creating an integrated drainage system that could keep the critically important access roads and set-down zones for the multi award winning Terminal 5 free of standing water required a whole series of bespoke ACO KerbDrain® units to be created. Designed to be installed within a shallow deck structure whilst retaining ACO KerbDrain's high hydraulic capacity and rapid intake performance, the individual units were manufactured in low-volume to the demanding tolerances, delivery schedules and budget requirements of this landmark project.

[Download the full case study](#) 

ACO KerbDrain® system overview

Making the right product selection

ACO KerbDrain® is available in Half Battered (HB) or Splayed (SP) profiles and has a variety of unit depths available for optimum scheme hydraulics.

To summarise the available options, the product selector opposite displays key features for each of the profiles and unit depths available.

CATCHMENT AREA	
*EXAMPLE RUN BASED ON 50m LENGTH TO OUTLET	
AVAILABILITY	
✓ AVAILABLE	✗ NOT AVAILABLE
HYDRAULIC CAPACITY	
📊 LOW	📊 MEDIUM
LOAD CLASS D 400	
LOAD CLASS D 400 PUBLIC HIGHWAYS, PARKING AREAS FOR ALL TYPES OF VEHICLES, DISTRIBUTION YARDS.	

† Long lasting corrosion protection



BS EN 1433
KM 538858

	HB255	HB305	HB405	HB480
HB PROFILE	Go to technical data	Go to technical data	Go to technical data	Go to technical data
				
UNIT DEPTH	255mm	305mm	405mm	480mm
HYDRAULIC CAPACITY	📊	📊	📊	📊
CATCHMENT AREA	154m ² *	386m ² *	894m ² *	1360m ² *
1M UNIT	✓	✓	✓	✗
TRANSITIONS TO	n/a	SP280	SP380	n/a
PEDESTRIAN CROSSING POINTS	✓	✓	✗	✗
RADIUS / MITRE UNITS	✗	✓	✗	✓
BUS STOP	✗	✓	✗	✓

	SP280	SP380	SP480
SP PROFILE	Go to technical data	Go to technical data	Go to technical data
			
UNIT DEPTH	280mm	380mm	480mm
HYDRAULIC CAPACITY	📊	📊	📊
CATCHMENT AREA	386m ² *	894m ² *	1490m ² *
1M UNIT	✓	✓	✗
TRANSITIONS TO	HB305	HB405	n/a

ACO KerbDrain® technical data

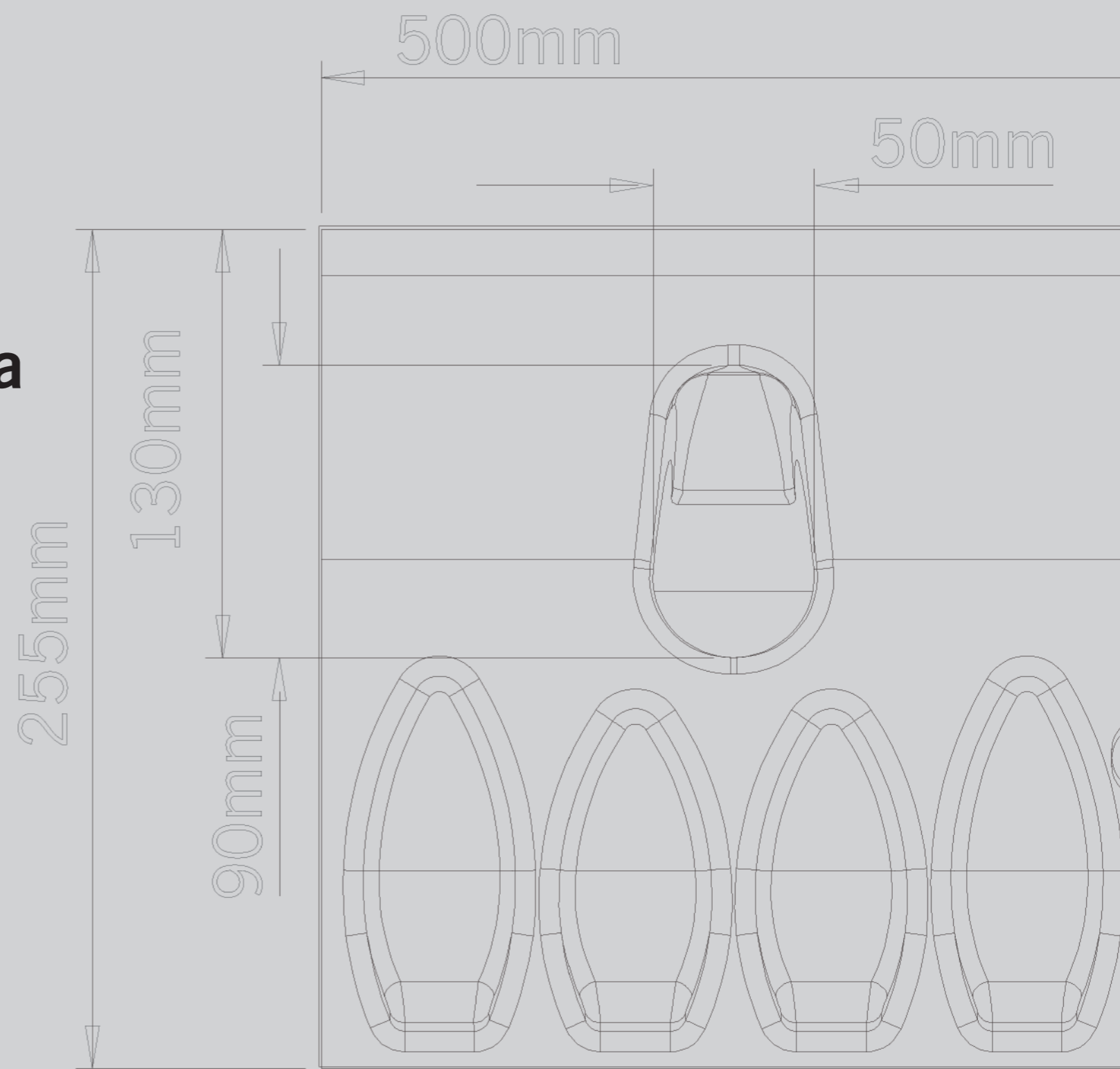

ACO KerbDrain® HB255

[Click here](#) for details regarding gullies for use with this system.

HB255 half battered kerb units

Product code	Description	Length (mm)	Width overall (mm)	Depth overall (mm)	Invert depth (mm)	Weight (kg)
7950	KDHB255 1000mm	1000	125	255	235	37.2
7958	KDHB255 500mm	500	125	255	235	18.5

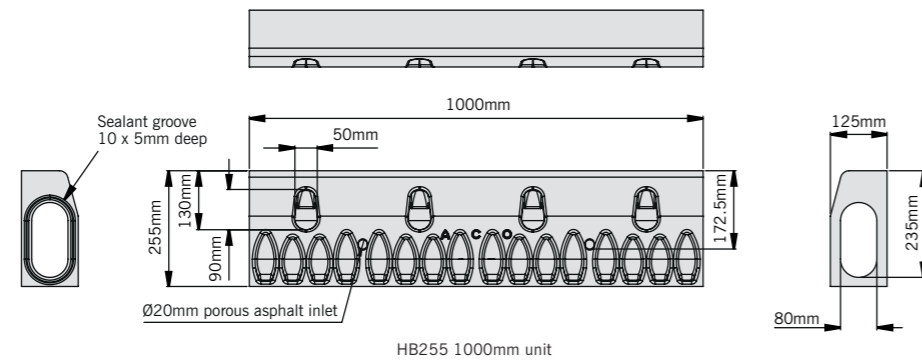

HB255 1000mm unit

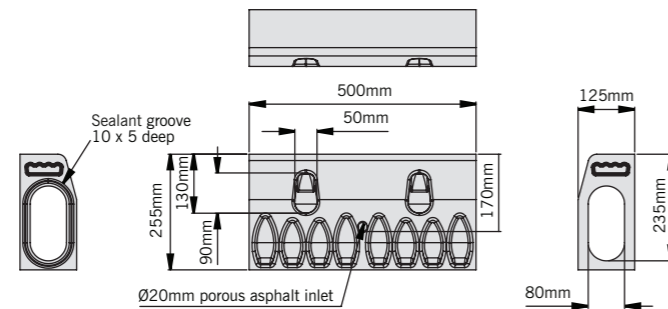

HB255 500mm unit

HB255 half battered rodding access unit

Product code	Description	Length (mm)	Width overall (mm)	Depth overall (mm)	Invert depth (mm)	Weight (kg)
7949	KDHB255 access unit*	500	125/150	255	235	23.3

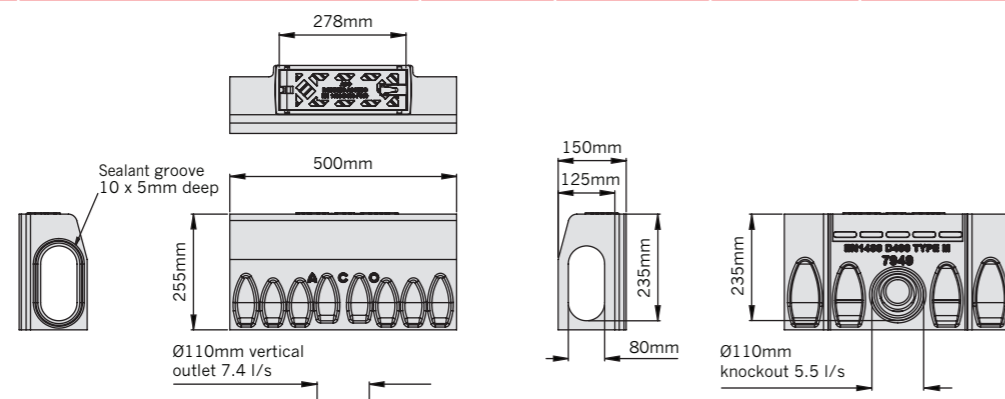

HB255 access unit

HB255 half battered flush drainable drop kerb units

Product code	Description	Length (mm)	Width overall (mm)	Depth overall (mm)	Invert depth (mm)	Weight (kg)
7956	KDHB255 LH drop kerb	1000	125/150	255/130	235/105	38.0
7957	KDHB255 RH drop kerb	1000	125/150	255/130	235/105	38.0

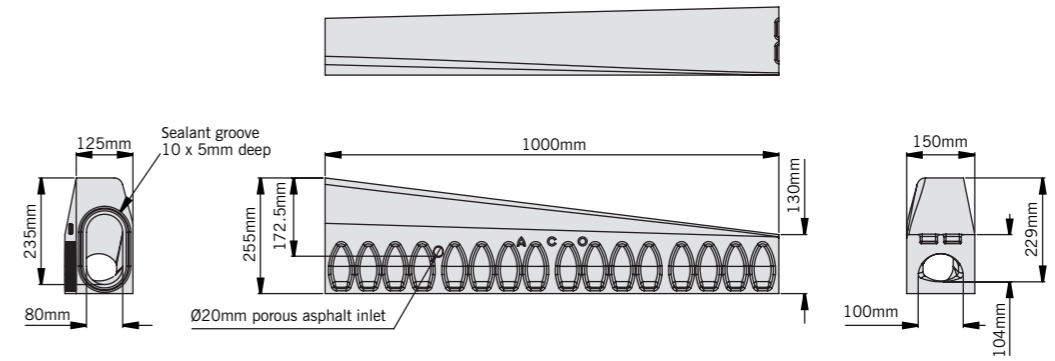

HB255 left hand drop kerb

HB255 half battered flush drainable centre stone unit

Product code	Description	Length (mm)	Width overall (mm)	Depth overall (mm)	Invert depth (mm)	Weight (kg)
7955	KDHB255 centre stone	1000	150	125	105	24.7

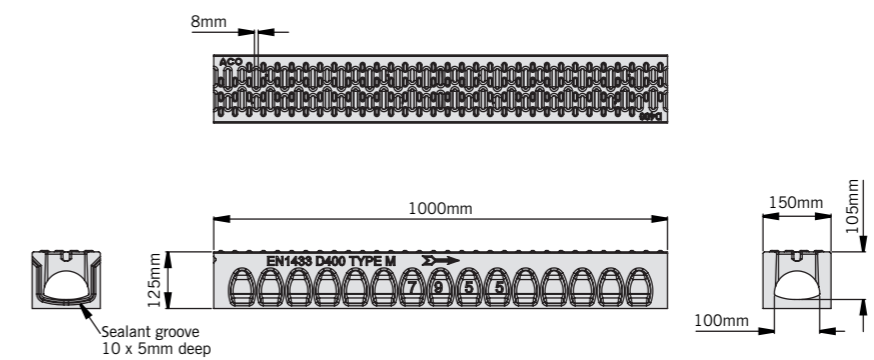

HB255 centre stone unit

HB255 half battered closing end cap

Product code	Description	Length (mm)	Width overall (mm)	Depth overall (mm)	Invert depth (mm)	Weight (kg)
4938	KDHB255 closing end cap	50	150	480	-	7.4

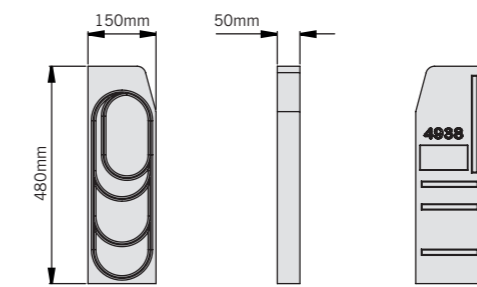

HB255 closing end cap

[Click here](#) for installation details

[Click here](#) for details of product hydraulic capacities

These products are subject to weight and dimensional tolerances. The dimensions shown on this page are for guidance purposes only.

* Access unit cover can be hinged at either end and orientated to suit traffic direction. Note: For details regarding the gully, foul air-traps and drain unions for use with this system please [click here](#).

ACO KerbDrain® HB305

[Click here](#) for details regarding gullies for use with this system.

HB305 half battered kerb units

Product code	Description	Length (mm)	Width overall (mm)	Depth overall (mm)	Invert depth (mm)	Weight (kg)
7959	KDHB305 1000mm	1000	150	305	280	53.1
7961	KDHB305 500mm	500	150	305	280	26.2
7972	KDHB305 500mm blind unit†	500	150	305	280	28.5
7960	KDHB305 250mm	250	150	305	280	12.0

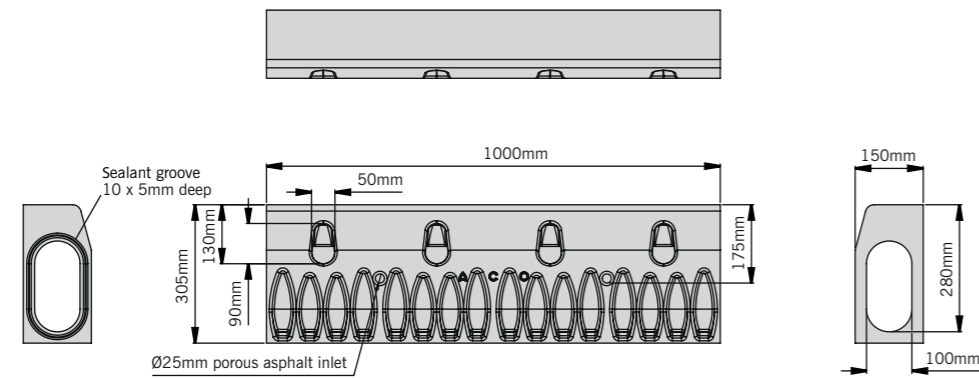

HB305 1000mm unit

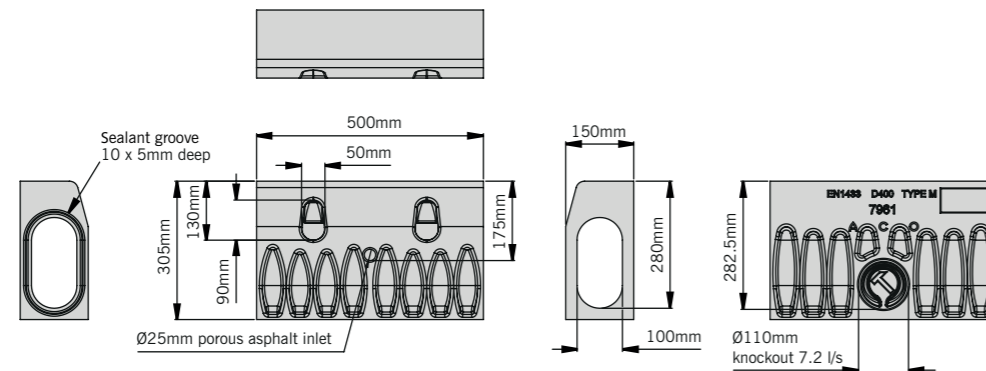

HB305 500mm unit

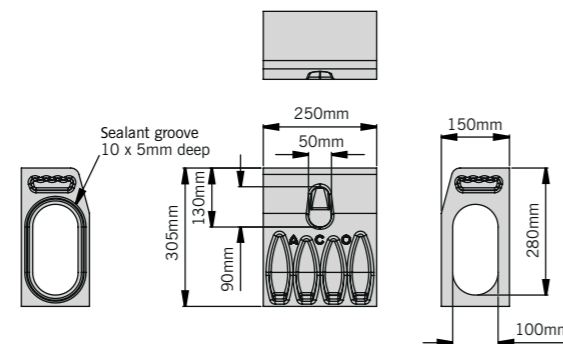

HB305 250mm unit

HB305 half battered rodding access unit

Product code	Description	Length (mm)	Width overall (mm)	Depth overall (mm)	Invert depth (mm)	Weight (kg)
7962	KDHB305 access unit*	500	150	305	280	28.7

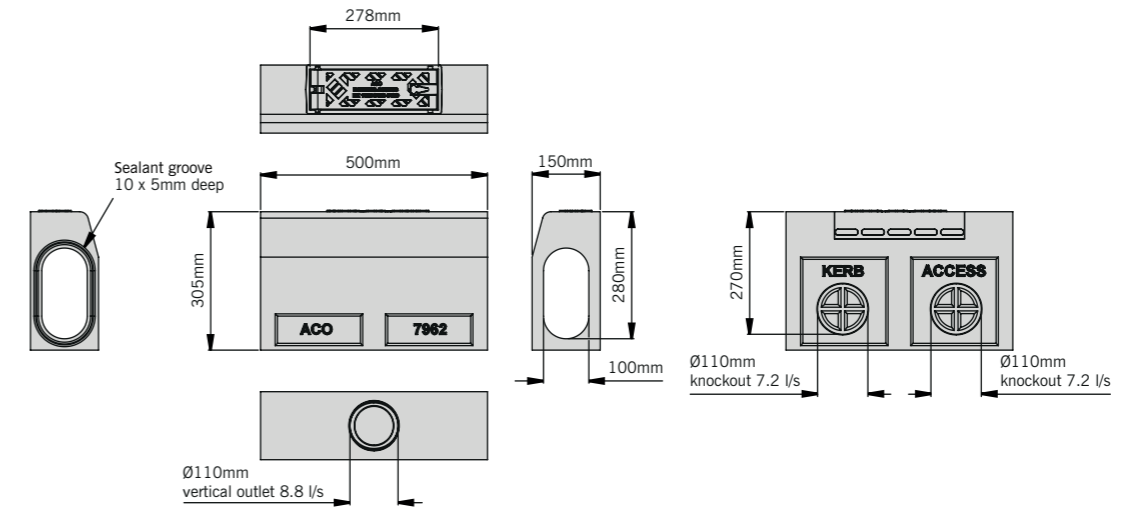

HB305 access unit

HB305 half battered drop kerb units

Product code	Description	Length (mm)	Width overall (mm)	Depth overall (mm)	Invert depth (mm)	Weight (kg)
7966	KDHB305 LH drop kerb	915	150	305/205	280/180	49.5
7967	KDHB305 RH drop kerb	915	150	305/205	280/180	49.5

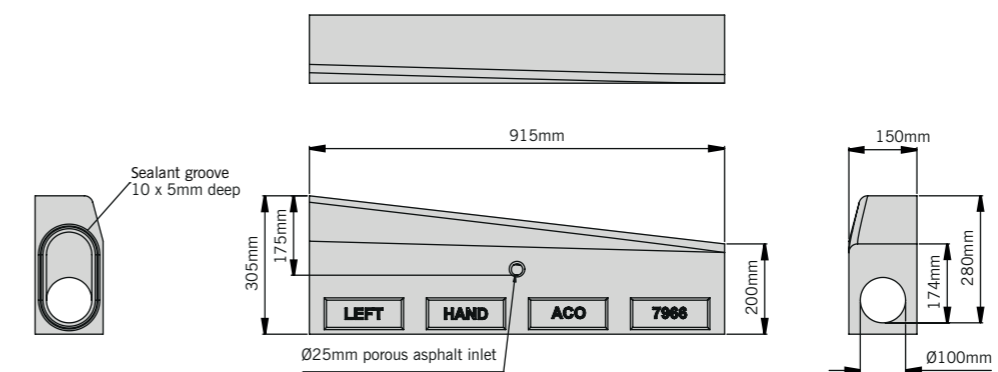

HB305 left hand drop kerb

[Click here](#) for installation details

[Click here](#) for details of product hydraulic capacities

These products are subject to weight and dimensional tolerances. The dimensions shown on this page are for guidance purposes only.

Note: For details regarding the gully, foul air-traps and drain unions for use with this system please [click here](#).

† Blind units are provided without surface water drainage inlets. *Access unit cover can be hinged at either end and orientated to suit traffic direction

ACO KerbDrain® HB305

[Click here](#) for details regarding gullies for use with this system

HB305 half battered centre stone unit with 25mm upstand

Product code	Description	Length (mm)	Width overall (mm)	Depth overall (mm)	Invert depth (mm)	Weight (kg)
7965	KDHB305 centre stone	915	150	205	180	43.5

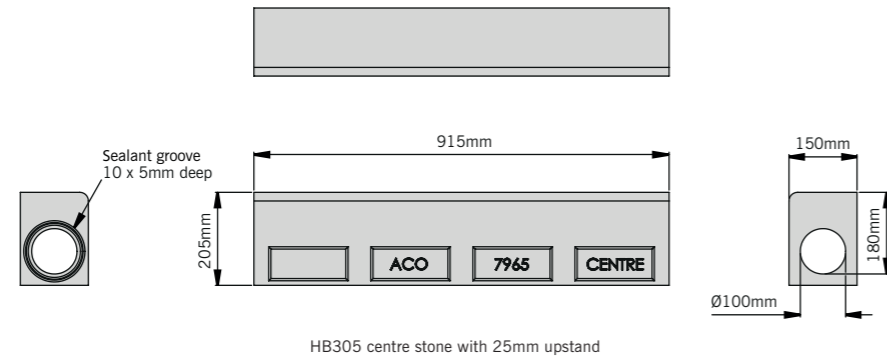

HB305 centre stone with 25mm upstand

HB305 half battered flush drainable drop kerb units

Product code	Description	Length (mm)	Width overall (mm)	Depth overall (mm)	Invert depth (mm)	Weight (kg)
7995	KDHB305 flush LH drop kerb	1500	150	305/180	280/155	75.5
7996	KDHB305 flush RH drop kerb	1500	150	305/180	280/155	75.5

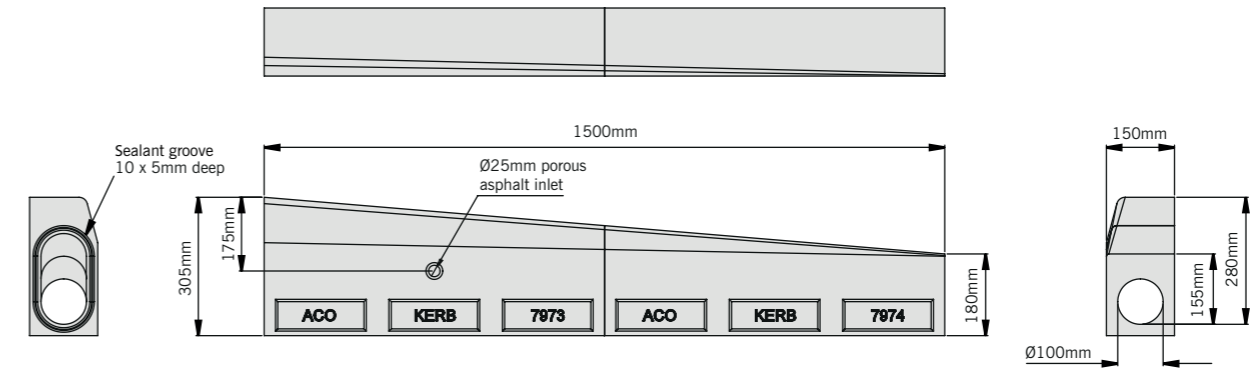

HB305 flush drainable left hand drop kerb

HB305 half battered perforated centre stone unit with 25mm upstand

Product code	Description	Length (mm)	Width overall (mm)	Depth overall (mm)	Invert depth (mm)	Weight (kg)
4982	KDHB305 perforated centre stone	915	150	205	180	42.9
4997	'Heelguard' insert (4 per unit required)†	50	-	-	-	0.1

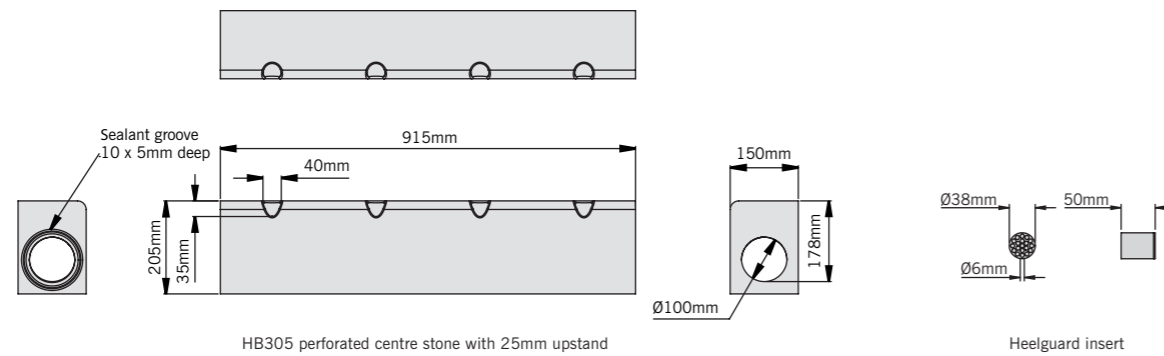

HB305 perforated centre stone with 25mm upstand

Heelguard insert

HB305 half battered flush drainable centre stone with 0-6mm upstand

Product code	Description	Length (mm)	Width overall (mm)	Depth overall (mm)	Invert depth (mm)	Weight (kg)
7992	KDHB305 drainable centre stone	1000	150	180	155	36.3

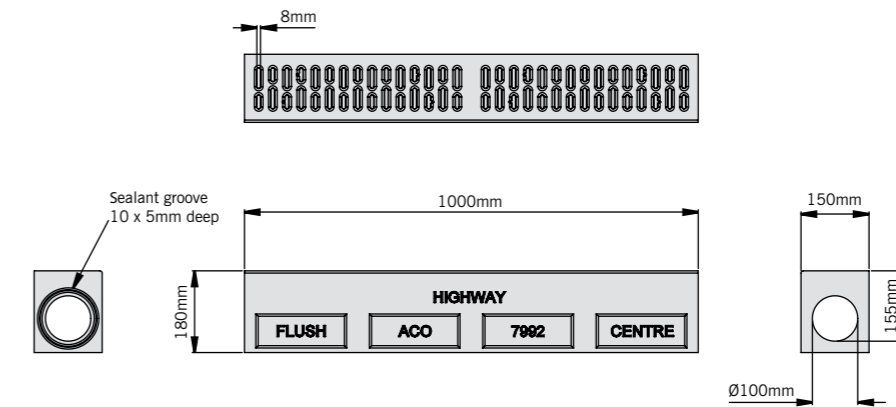

HB305 flush drainable centre stone with 0-6mm upstand

[Click here](#) for installation details

[Click here](#) for details of product hydraulic capacities

These products are subject to weight and dimensional tolerances. The dimensions shown on this page are for guidance purposes only.

Note: For details regarding the gully, foul air-traps and drain unions for use with this system please [click here](#).
† Heelguard inserts can be fitted in the inlets of perforated centre stones.

ACO KerbDrain® HB305

[Click here](#) for details regarding gullies for use with this system

HB305 half battered flush drainable drop kerb units with 6m external radius

Product code	Description	Length (mm)	Width overall (mm)	Depth overall (mm)	Invert depth (mm)	Weight (kg)
4998	KDHB305 LH drop kerb	1500	150	305/180	280/155	77.5
4999	KDHB305 RH drop kerb	1500	150	305/180	280/155	77.5

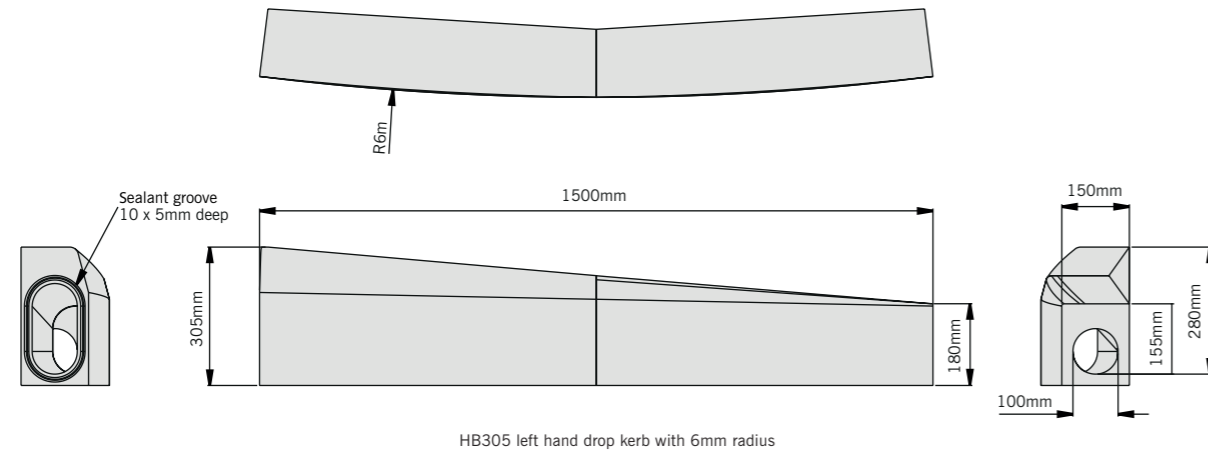

HB305 half battered flush drainable centre stone with 6m external radius

Product code	Description	Length (mm)	Width overall (mm)	Depth overall (mm)	Invert depth (mm)	Weight (kg)
4985	KDHB305 flush drainable centre stone	496	150	180	155	18.3

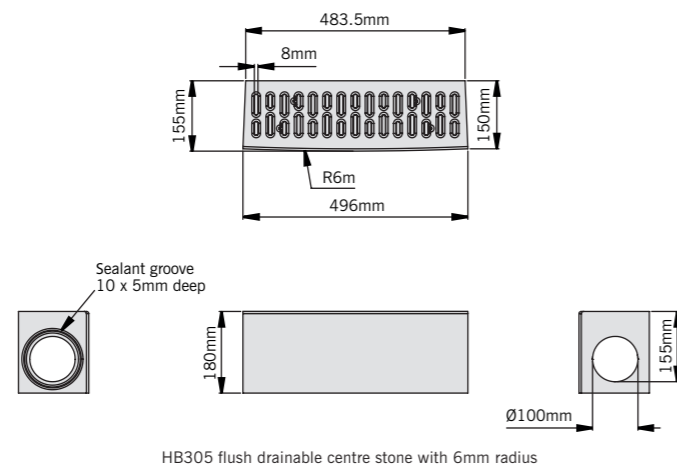

HB305 half battered mitre units

Product code	Description	Length (mm)	Width overall (mm)	Depth overall (mm)	Invert depth (mm)	Weight (kg)
7968	KDHB305 7-6m external mitre	500/487	150	305	280	26.9
7969	KDHB305 10-8m external mitre	500/490	150	305	280	26.7
7970	KDHB305 25-11m external mitre	500/493	150	305	280	26.5
7971	KDHB305 25-11m internal mitre	500/503	150	305	280	26.7

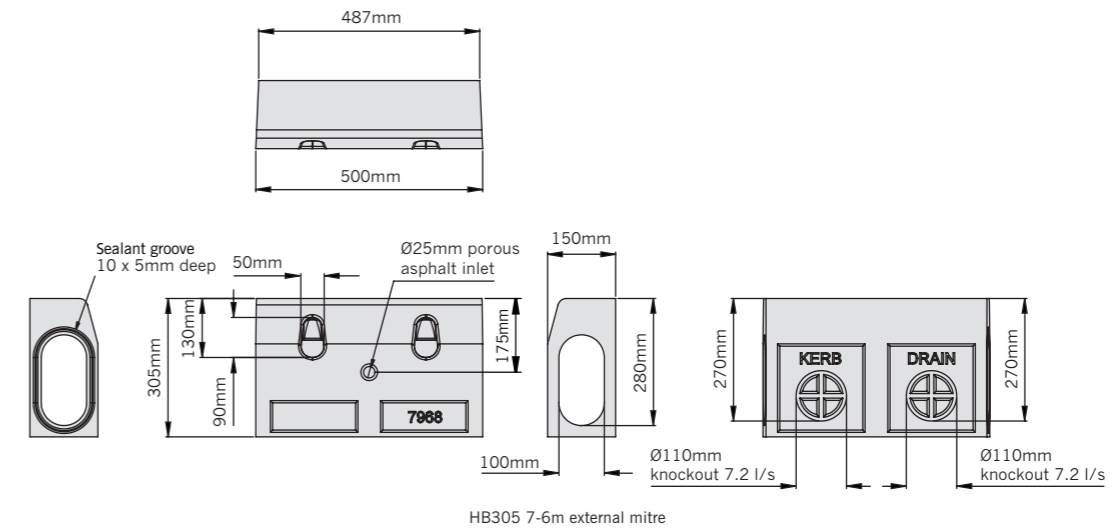

HB305 half battered 6m external radius unit

Product code	Description	Length (mm)	Width overall (mm)	Depth overall (mm)	Invert depth (mm)	Weight (kg)
4984	KDHB305 6m external radius	496	150	305	280	27.8

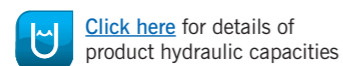
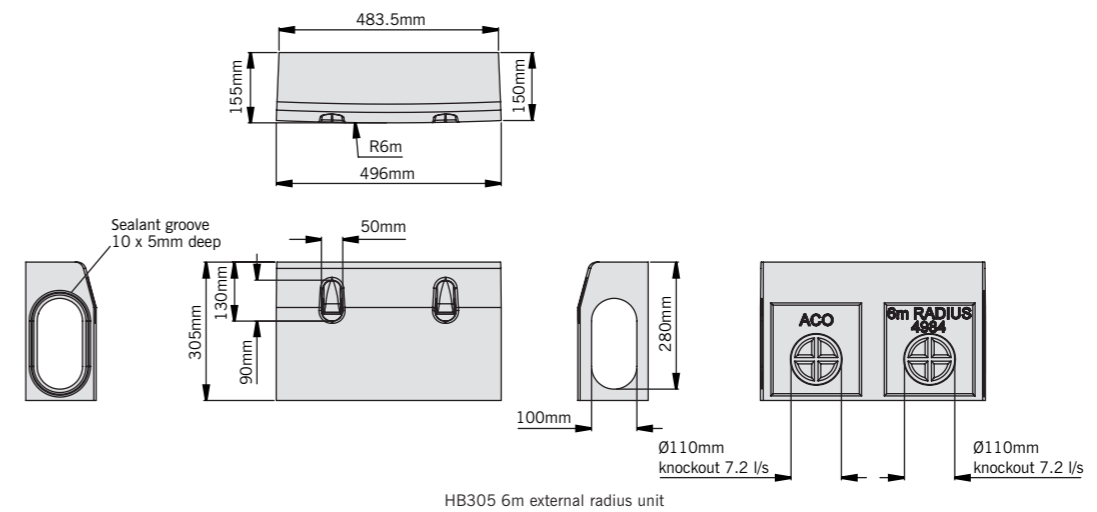

These products are subject to weight and dimensional tolerances. The dimensions shown on this page are for guidance purposes only.

Note: For details regarding the gully, foul air-traps and drain unions for use with this system please [click here](#).

ACO KerbDrain® HB305

[Click here](#) for details regarding gullies for use with this system

HB305 half battered 1.8m external radius kerb unit

Product code	Description	Length (mm)	Width overall (mm)	Depth overall (mm)	Invert depth (mm)	Weight (kg)
4990	KDHB305 1.8m radius	470	150	305	280	27.0

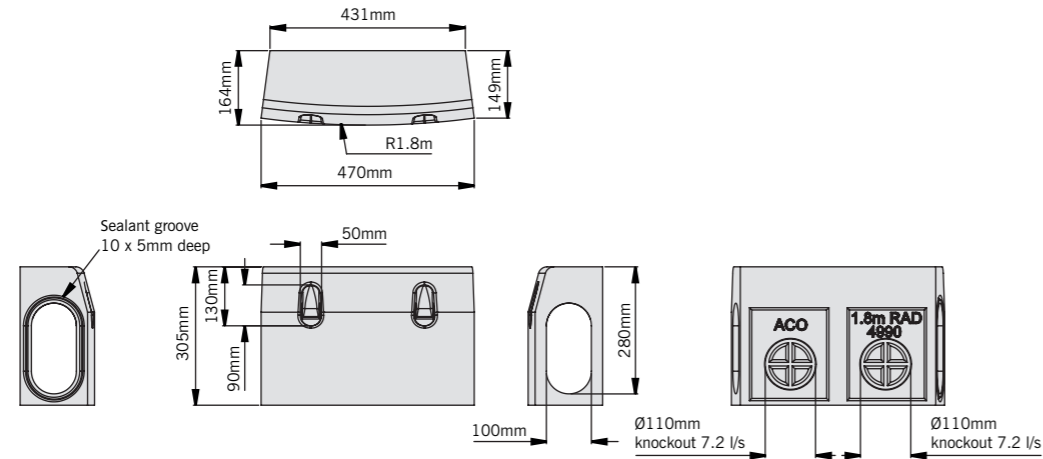

HB305 1.8m external radius kerb unit

HB305 half battered quadrant unit

Product code	Description	Length (mm)	Width overall (mm)	Depth overall (mm)	Invert depth (mm)	Weight (kg)
4992	KDHB305 quadrant	305	305	305	280	32.0

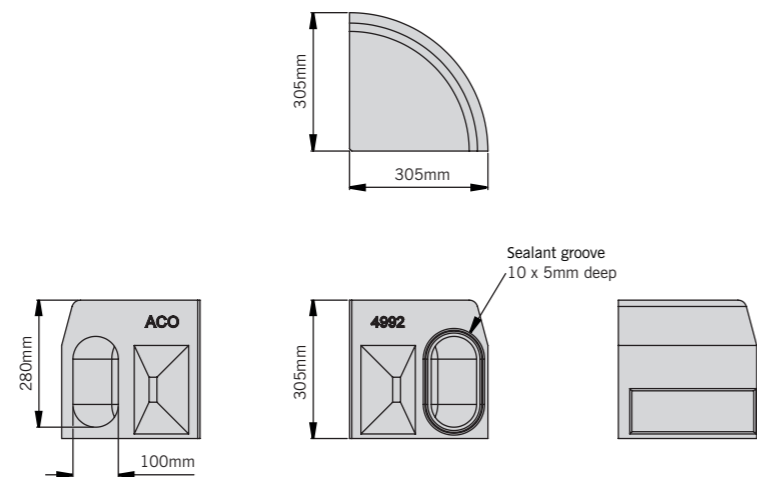

HB305 quadrant unit

HB305 half battered 90° internal angle unit

Product code	Description	Length (mm)	Width overall (mm)	Depth overall (mm)	Invert depth (mm)	Weight (kg)
4991	KDHB305 internal angle	305	150	305	280	24.7

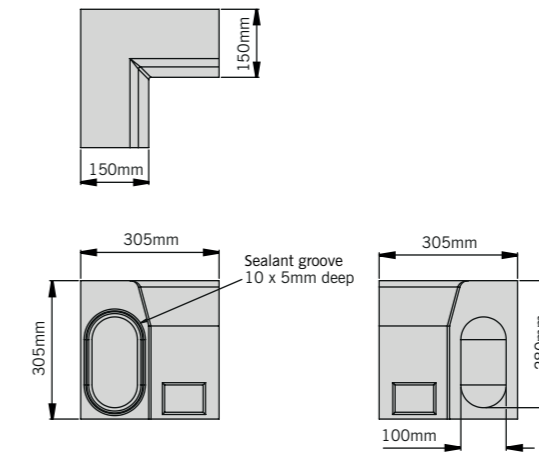

HB305 internal angle

HB305 half battered end caps

Product code	Description	Length (mm)	Width overall (mm)	Depth overall (mm)	Invert depth (mm)	Weight (kg)
4938	KDHB305 closing end cap	50	150	480	-	7.4
7964	KDHB305 LH inlet/outlet end cap†	50	150	305	280	3.9
7963	KDHB305 RH inlet/outlet end cap†	50	150	305	280	3.9

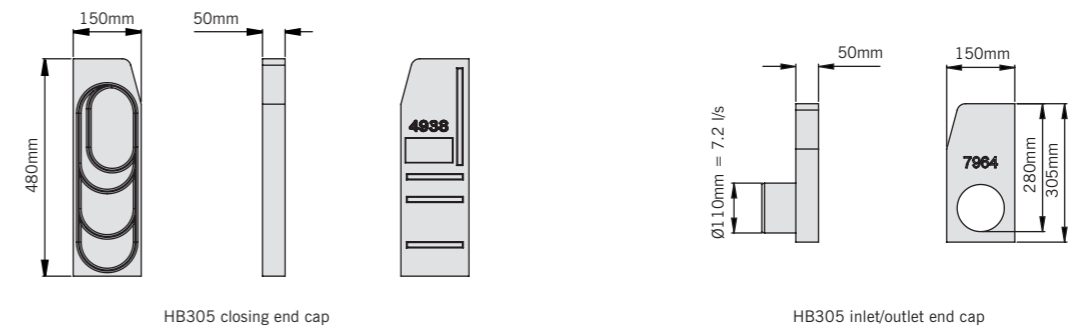

HB305 closing end cap

HB305 inlet/outlet end cap

 [Click here](#) for installation details

 [Click here](#) for details of product hydraulic capacities

These products are subject to weight and dimensional tolerances. The dimensions shown on this page are for guidance purposes only.

Note: For details regarding the gully, foul air-traps and drain unions for use with this system please [click here](#).
† Inlet/outlet endcaps are designated LH or RH when viewed from the carriageway.

ACO KerbDrain® HB405

[Click here](#) for details regarding gullies for use with this system

HB405 half battered kerb units

Product code	Description	Length (mm)	Width overall (mm)	Depth overall (mm)	Invert depth (mm)	Weight (kg)
4232	KDHB405 1000mm	1000	150	405	380	63.5
4231	KDHB405 500mm	500	150	405	380	30.9
4230	KDHB405 500mm blind unit†	500	150	405	780	32.0

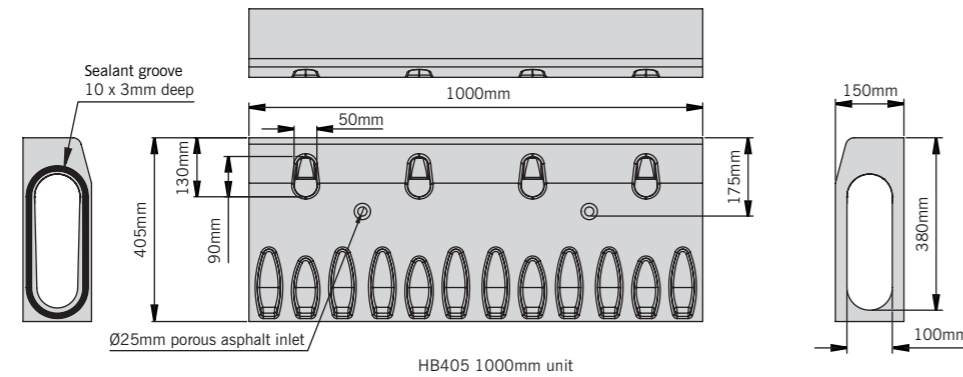

HB405 1000mm unit

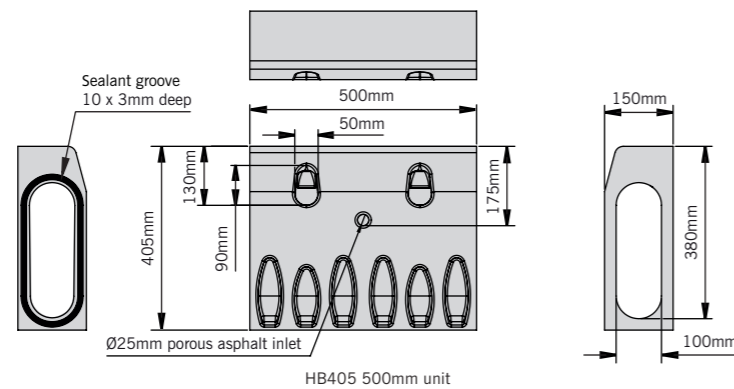

HB405 500mm unit

HB405 half battered rodding access units

Product code	Description	Length (mm)	Width overall (mm)	Depth overall (mm)	Invert depth (mm)	Weight (kg)
4233	KDHB405 access unit*	500	150	405	380	34.3

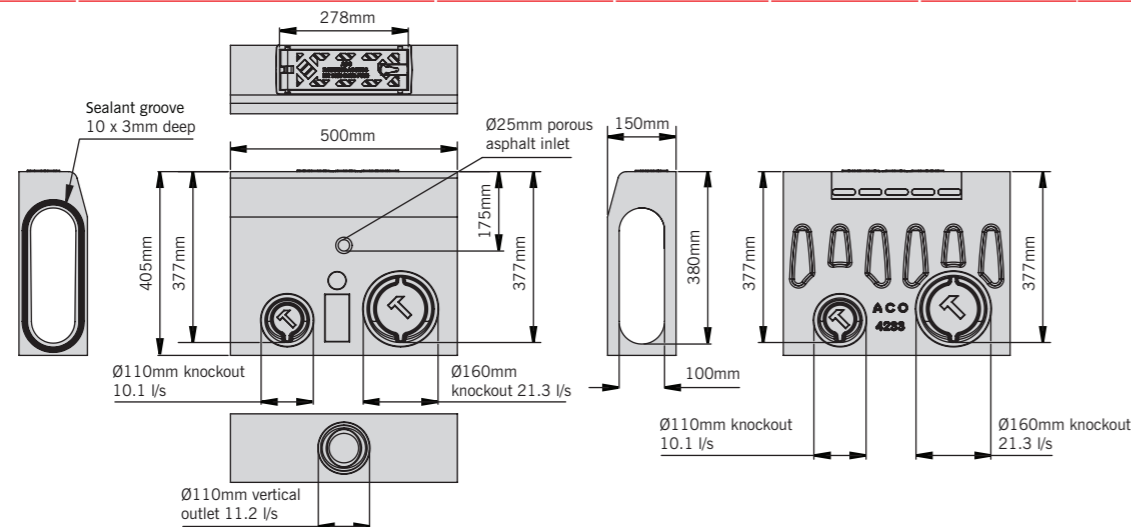

HB405 access unit

HB405 half battered drop kerb units

Product code	Description	Length (mm)	Width overall (mm)	Depth overall (mm)	Invert depth (mm)	Weight (kg)
4234	KDHB405 LH drop kerb	1000	150	405/305	380/280	62.1
4235	KDHB405 RH drop kerb	1000	150	405/305	380/280	62.1

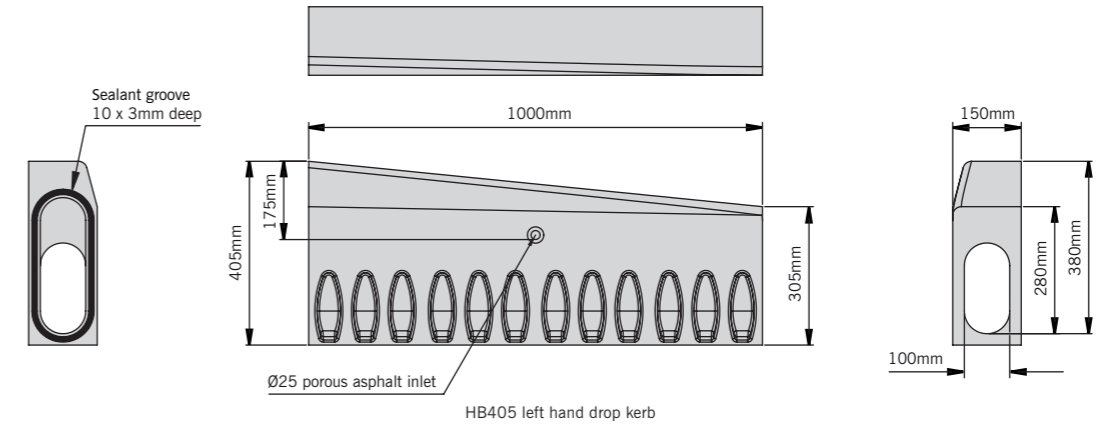

HB405 left hand drop kerb

HB405 half battered centre stone unit

Product code	Description	Length (mm)	Width overall (mm)	Depth overall (mm)	Invert depth (mm)	Weight (kg)
4236	KDHB405 centre stone	1000	150	305	280	60.1

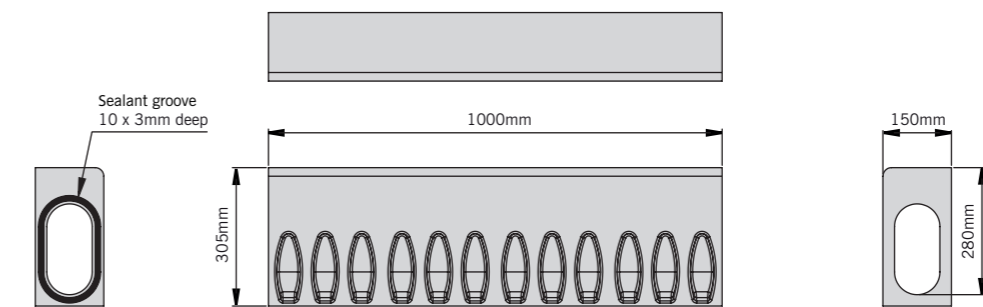

HB405 centre stone

HB405 half battered end caps

Product code	Description	Length (mm)	Width overall (mm)	Depth overall (mm)	Invert depth (mm)	Weight (kg)
4938	KDHB405 closing end cap	50	150	480	-	7.4
4237	KDHB405 LH inlet/outlet end cap††	50	150	405	380	5.7
4238	KDHB405 RH inlet/outlet end cap††	50	150	405	380	5.7

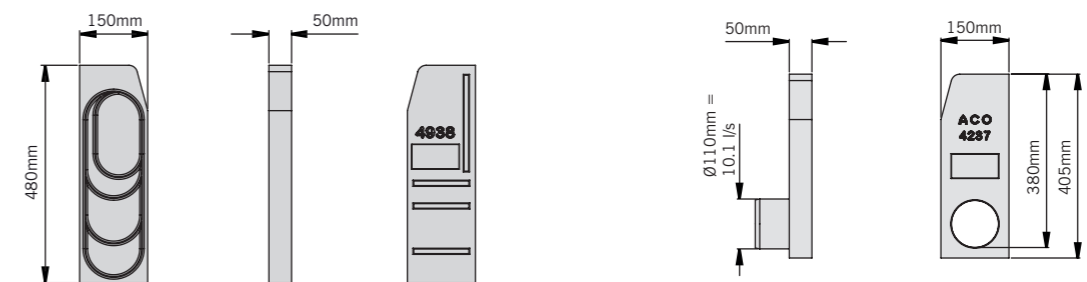

HB305 closing end cap

HB305 LH inlet/outlet end cap

[Click here](#) for installation details

[Click here](#) for details of product hydraulic capacities

These products are subject to weight and dimensional tolerances. The dimensions shown on this page are for guidance purposes only.

† Blind units are provided without surface water drainage inlets

* Access unit cover can be hinged at either end and orientated to suit traffic direction. †† Inlet/outlet endcaps are designated LH or RH when viewed from the carriageway.

Note: For details regarding the gully, foul air-traps and drain unions for use with this system please [click here](#).

ACO KerbDrain® HB480

[Click here](#) for details regarding gullies for use with this system

HB480 half battered kerb units

Product code	Description	Length (mm)	Width overall (mm)	Depth overall (mm)	Invert depth (mm)	Weight (kg)
4926	KDHB480 500mm	500	150	480	455	35.9
4923	KDHB480 500mm blind unit†	500	150	480	455	36.4

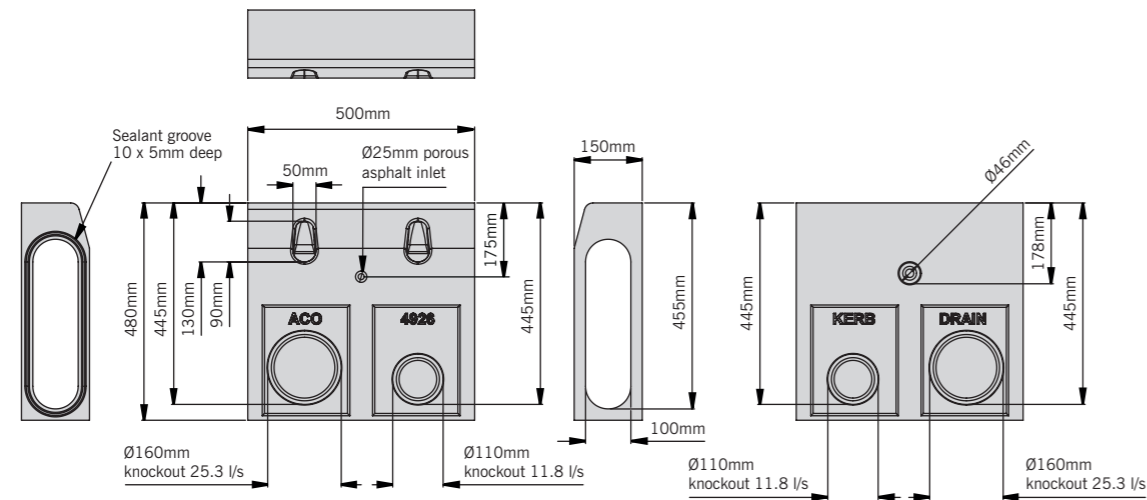

HB480 500mm unit

HB480 half battered rodding access unit

Product code	Description	Length (mm)	Width overall (mm)	Depth overall (mm)	Invert depth (mm)	Weight (kg)
4927	KDHB480 access unit*	500	150	480	455	36.7

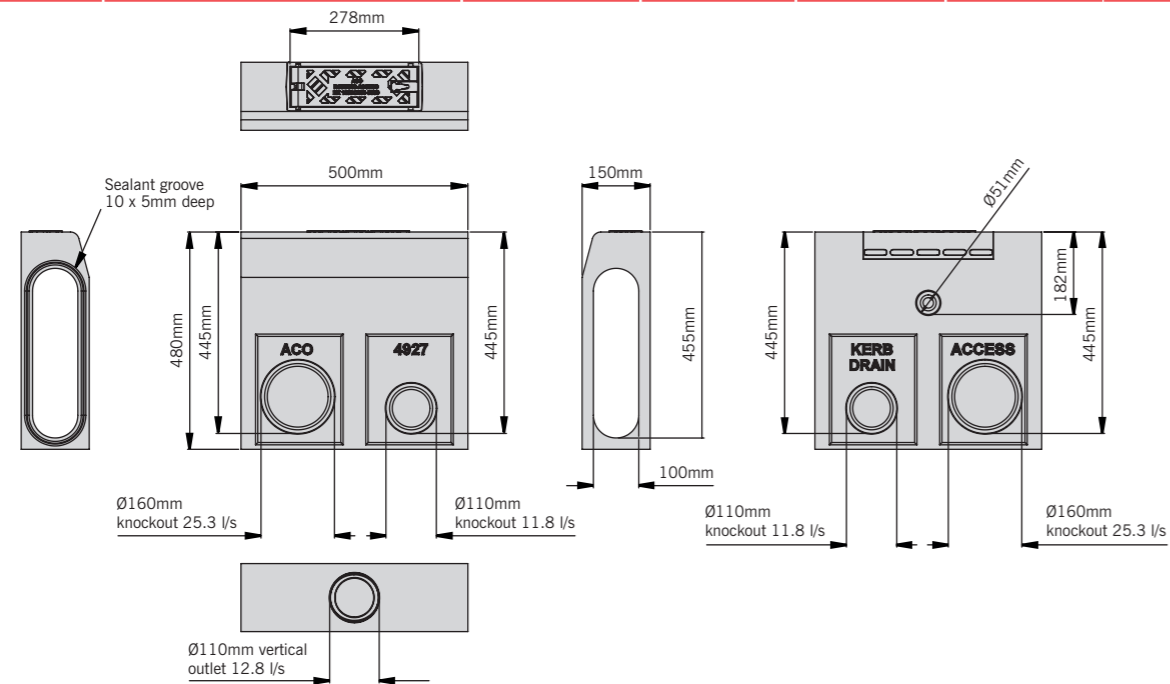

HB480 access unit

HB480 half battered drop kerb units

Product code	Description	Length (mm)	Width overall (mm)	Depth overall (mm)	Invert depth (mm)	Weight (kg)
4931	KDHB480 LH drop kerb	915	150	480/375	455/350	66.7
4932	KDHB480 RH drop kerb	915	150	480/375	455/350	66.7

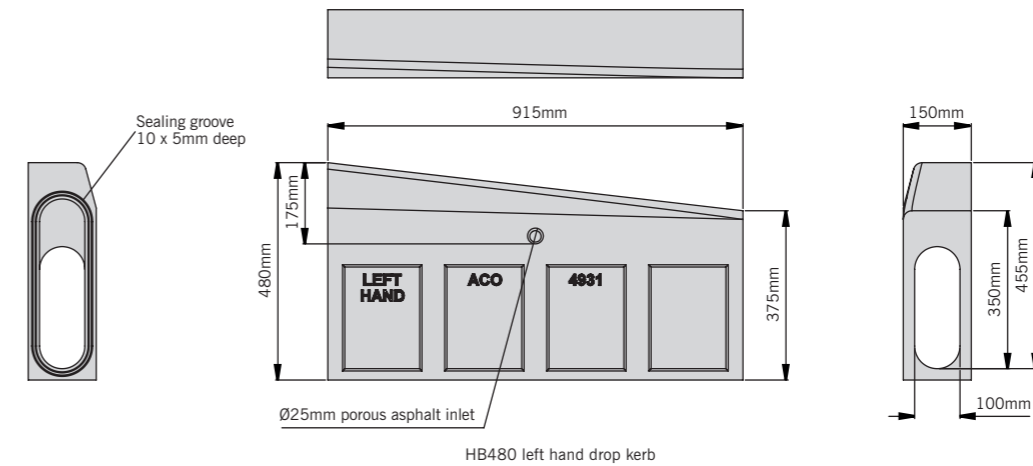

HB480 left hand drop kerb

HB480 half battered centre stone unit with 25mm upstand

Product code	Description	Length (mm)	Width overall (mm)	Depth overall (mm)	Invert depth (mm)	Weight (kg)
4933	KDHB480 centre stone	915	150	375	350	59.8

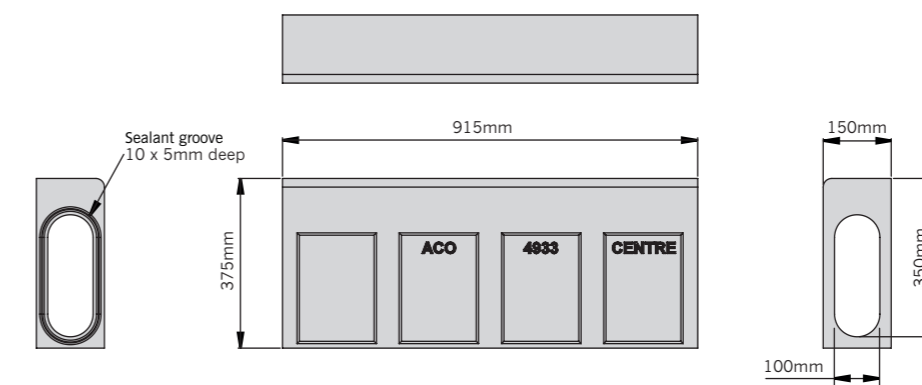

HB480 centre stone with 25mm upstand

[Click here](#) for installation details

[Click here](#) for details of product hydraulic capacities

These products are subject to weight and dimensional tolerances. The dimensions shown on this page are for guidance purposes only.

† Blind units are provided without surface water drainage inlets

* Access unit cover can be hinged at either end and orientated to suit traffic direction.

Note: For details regarding the gully, foul air-traps and drain unions for use with this system please [click here](#).

ACO KerbDrain® HB480

[Click here](#) for details regarding gullies for use with this system

HB480 half battered perforated centre stone unit with 25mm upstand

Product code	Description	Length (mm)	Width overall (mm)	Depth overall (mm)	Invert depth (mm)	Weight (kg)
4983	KDHB480 perforated centre stone	915	150	375	350	59.7
4997	'Heelguard' insert (4 per unit required)†	50	-	-	-	0.1

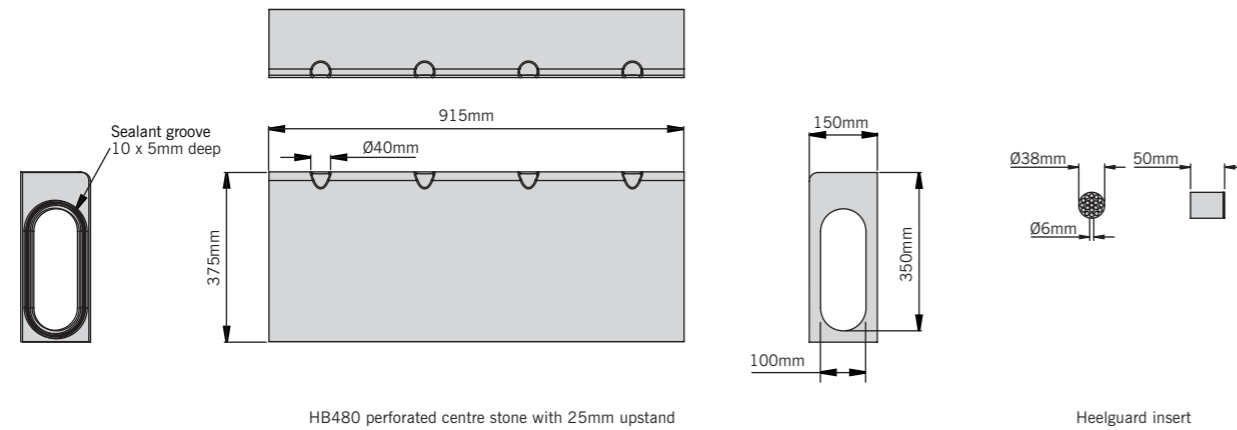

HB480 perforated centre stone with 25mm upstand

Heelguard insert

HB480 half battered bus stop transition kerb units

Product code	Description	Length (mm)	Width overall (mm)	Depth overall (mm)	Invert depth (mm)	Weight (kg)
4965	KDHB480 LH BS transition kerb	1000	150	535/480	455/510	83.4
4966	KDHB480 RH BS transition kerb	1000	150	535/480	455/510	83.4

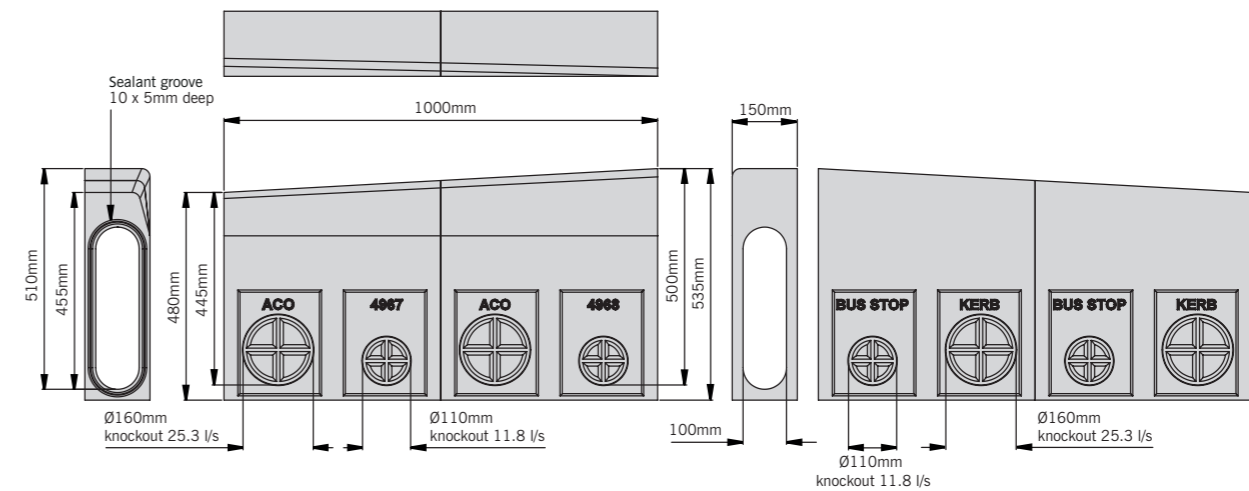

HB480 left hand bus stop transition kerb

HB480 half battered bus stop kerb unit with 180mm upstand

Product code	Description	Length (mm)	Width overall (mm)	Depth overall (mm)	Invert depth (mm)	Weight (kg)
4964	KDHB480 bus stop kerb*	500	150	535	510	44.9

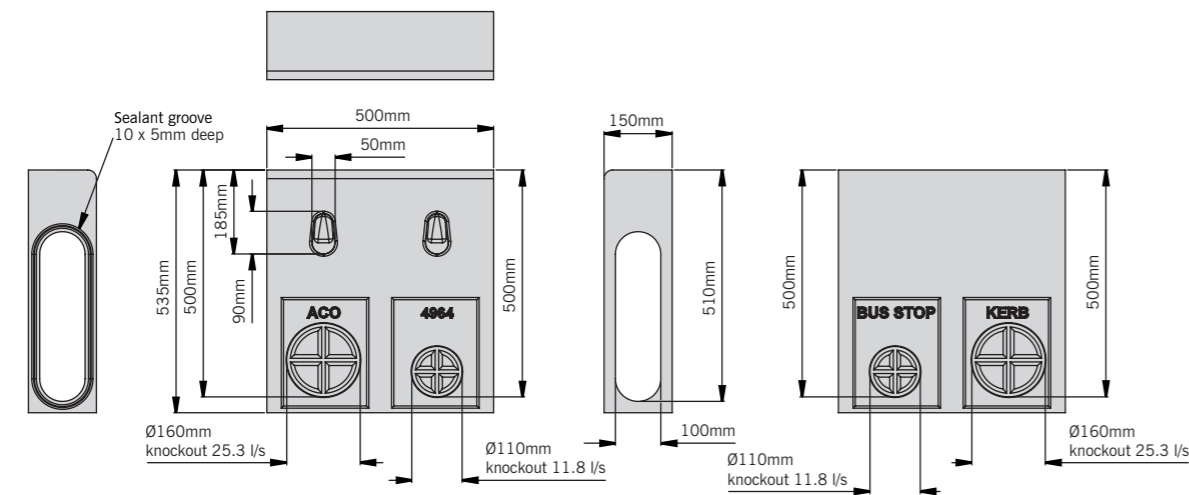

HB480 bus stop kerb

HB480 half battered mitre units

Product code	Description	Length (mm)	Width overall (mm)	Depth overall (mm)	Invert depth (mm)	Weight (kg)
4934	KDHB480 7-6m external mitre	500/487	150	480	455	36.2
4935	KDHB480 10-8m external mitre	500/490	150	480	455	35.7
4936	KDHB480 25-11m external mitre	500/493	150	480	455	35.2
4937	KDHB480 25-11m internal mitre	500/503	150	480	455	36.1

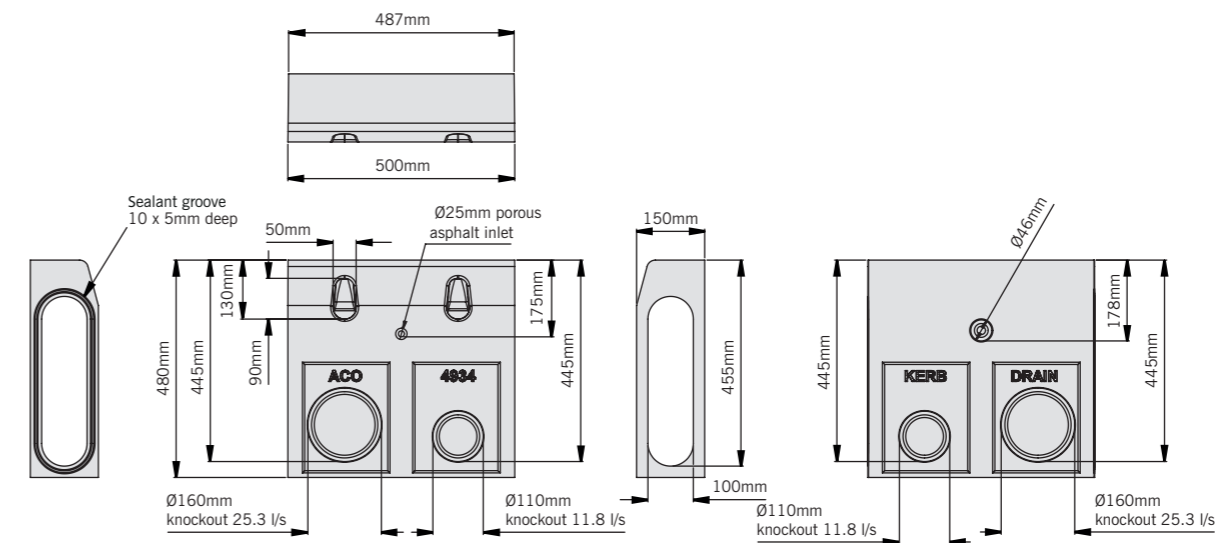

HB480 7-6m external mitre

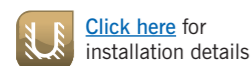

[Click here](#) for installation details



[Click here](#) for details of product hydraulic capacities

These products are subject to weight and dimensional tolerances. The dimensions shown on this page are for guidance purposes only.

† Heelguard inserts can be fitted within the inlets of perforated centre stones.

*HB305 bus stop kerb units also available upon request.

Note: For details regarding the gully, foul air-traps and drain unions for use with this system please [click here](#).

ACO KerbDrain® HB480

[Click here](#) for details regarding gullies for use with this system

HB480 half battered cable loop unit

Product code	Description	Length (mm)	Width overall (mm)	Depth overall (mm)	Invert depth (mm)	Weight (kg)
4943	KDHB480 cable loop	150	150	480	455	12.2

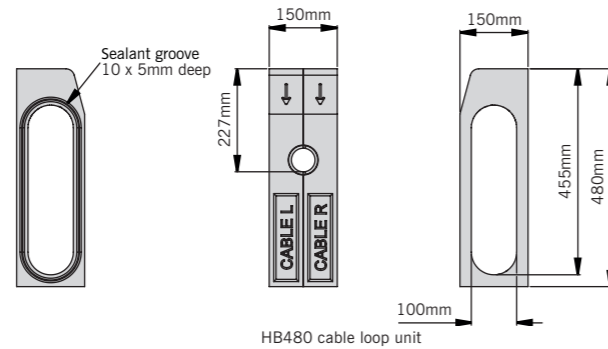

HB480 half battered junction channel unit - black

Product code	Description	Length (mm)	Width overall (mm)	Depth overall (mm)	Invert depth (mm)	Weight (kg)
32301	KDHB480 junction channel	500	160	350	325	26.0

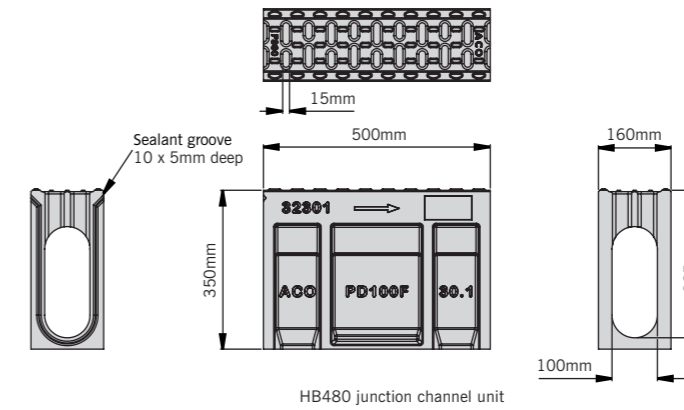

HB480 half battered end caps

Product code	Description	Length (mm)	Width overall (mm)	Depth overall (mm)	Invert depth (mm)	Weight (kg)
4938	KDHB480 closing end cap	50	150	480	-	7.4
4939	KDHB480 LH inlet/outlet end cap†	50	150	480	455	5.9
4940	KDHB480 RH inlet/outlet end cap†	50	150	480	455	5.9

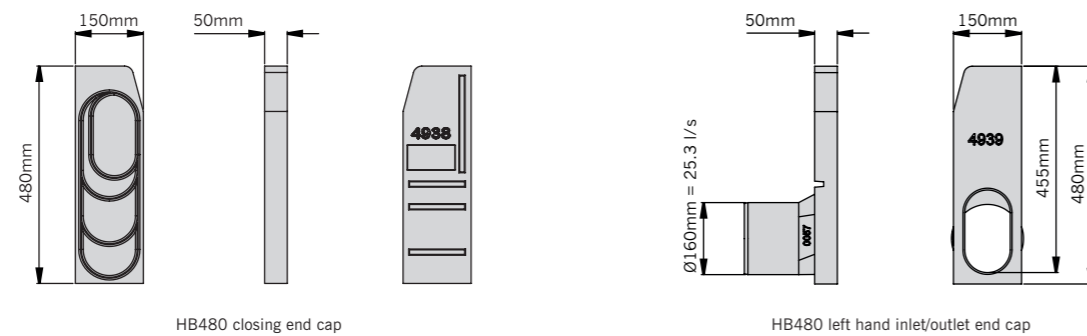

HB480 half battered junction channel access unit – black

Product code	Description	Length (mm)	Width overall (mm)	Depth overall (mm)	Invert depth (mm)	Weight (kg)
32303	KDHB480 junction access unit	500	160	350	325	31.0

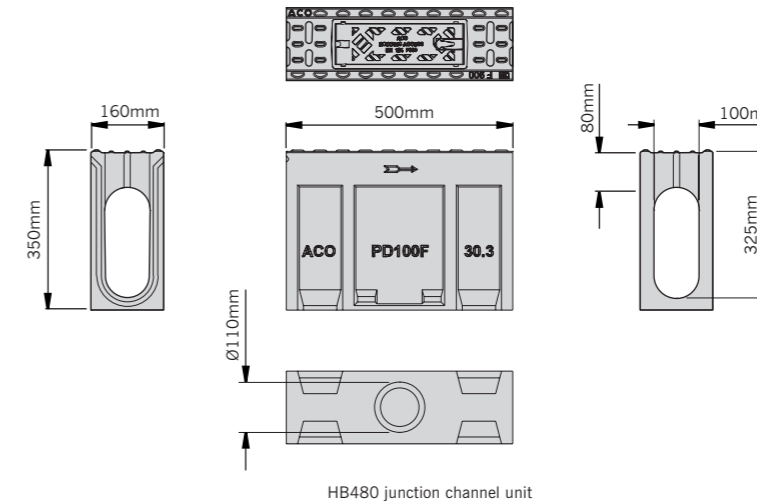

HB480 half battered junction channel inlet/outlet end cap

Product code	Description	Length (mm)	Width overall (mm)	Depth overall (mm)	Invert depth (mm)	Weight (kg)
32308	KDHB480 junction end cap	25	160	350	325	2.1

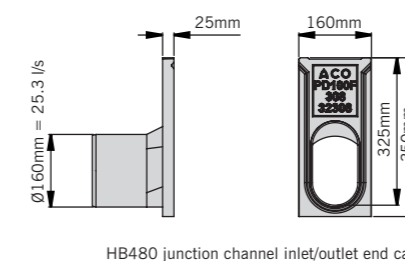

[Click here](#) for installation details

[Click here](#) for details of product hydraulic capacities

These products are subject to weight and dimensional tolerances. The dimensions shown on this page are for guidance purposes only.

† Inlet / outlet end caps are designated LH or RH when viewed from carriageway.
Note: For details regarding the gully, foul air-traps and drain unions for use with this system please [click here](#).

ACO KerbDrain® half battered gully

ACO KerbDrain® half battered gully units provide the outfall connection of the system to traditional underground drainage or road gullies, management of silt, and access for maintenance and cleaning. The gully unit also provides fast and simple connection between any sizes of half battered unit within the ACO KerbDrain® range.

Gullies are supplied with a ductile iron cover and frame and a polymer concrete unit for channel connection. These two components form the top assembly for all ACO KerbDrain® gully options. The ductile iron cover of the top assembly is lockable and for improved safety to road users can be orientated to suit traffic direction.

The ACO KerbDrain® gully top assembly can be specified on its own or in conjunction with four polymer concrete base options which allow drainage designs to be optimised for silt and hydraulic capacity or outlet connection.

Available gully base options are shallow and deep units, deep unit with roddable foul air trap or Ø450mm road gully connector. All gully base units are provided with outlet connections for Ø160mm or Ø200mm pipe and supplied with a galvanised steel gully bucket. For full details please see table below.



ACO KerbDrain® half battered gully units

Product code	Description	Length (mm)	Width overall (mm)	Depth overall (mm)	Invert depth (mm)	Weight (kg)
4928	Top assembly KDG	500	390	520	-	76.8
4182	Top and shallow base assembly KD610	500	390	870	845	107.4
4183	Top and deep base assembly KD611	500	390	1025	750/955	116.3
4184	Top and roddable deep base assembly KD612RE	500	390	1025	750/780	126.5
4185	Top and road gully connector Ø450mm KD615	500	390	545	-	88.1
1616	Gully bucket	395	250	330	-	4.7

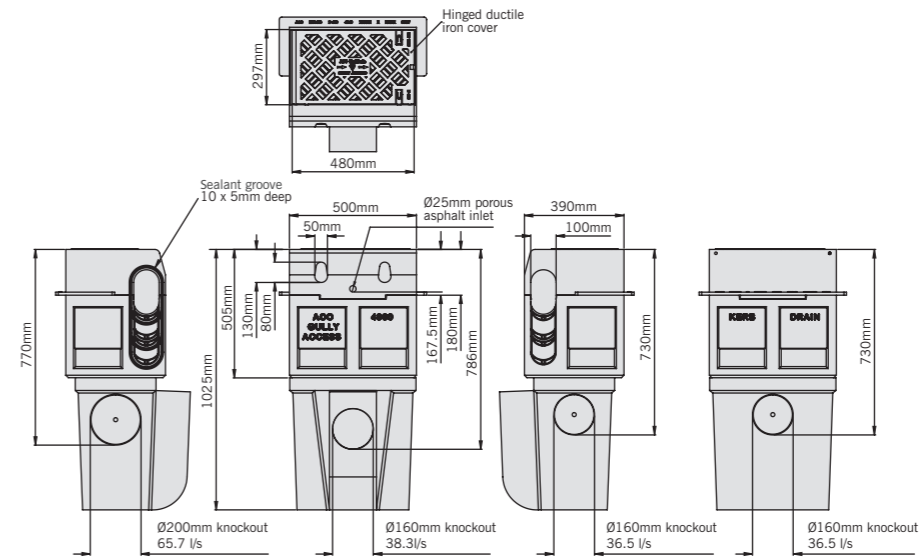

Top and roddable deep base assembly KD612RE

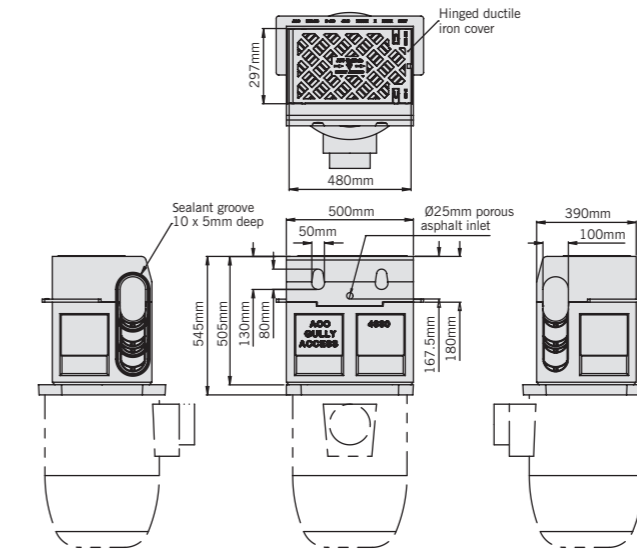

Top and road gully connector KD615

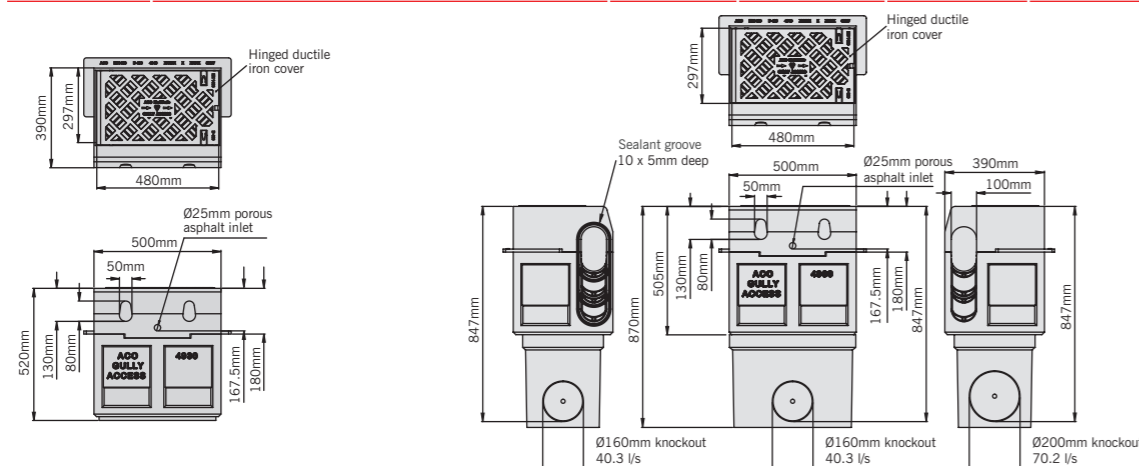

Top assembly KDG

Top and shallow base assembly KD610

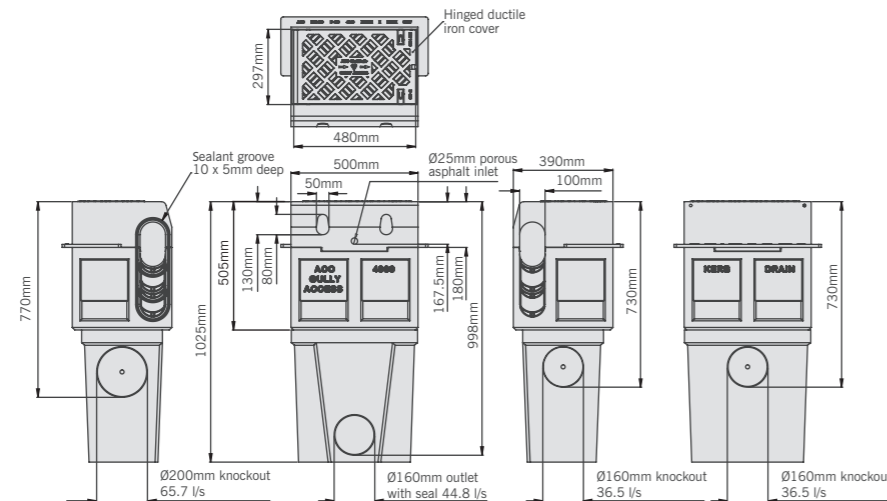

Top and deep base assembly KD611

Drain unions and foul air-trap

Product code	Description	Length (mm)	Width overall (mm)	Depth overall (mm)	Invert depth (mm)	Invert type	Weight (kg)
0056	820 Drain union PVC-U Ø110mm	100	110	-	-	-	0.1
0058	822 Drain union PVC-U Ø160mm	150	160	-	-	-	0.5
2723	823 Drain union PVC-U Ø200mm	200	200	-	-	-	0.6
2638	922 Foul air-trap PVC-U Ø160mm	-	160	-	-	-	1.9

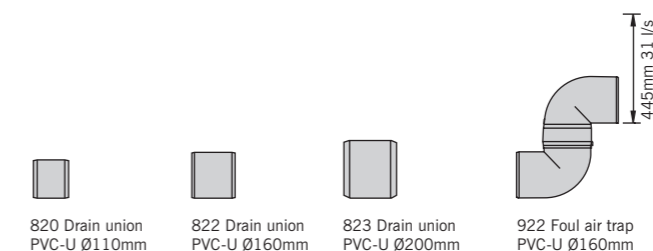

These products are subject to weight and dimensional tolerances. The dimensions shown on this page are for guidance purposes only.

ACO KerbDrain® SP280

[Click here](#) for details regarding gullies for use with this system

SP280 splayed kerb units

Product Code	Description	Length (mm)	Width Overall (mm)	Depth Overall (mm)	Invert depth (mm)	Weight (kg)
7930	KDSP280 1000mm	1000	150	280	255	44.9
7935	KDSP280 500mm	500	280	255	22.2	

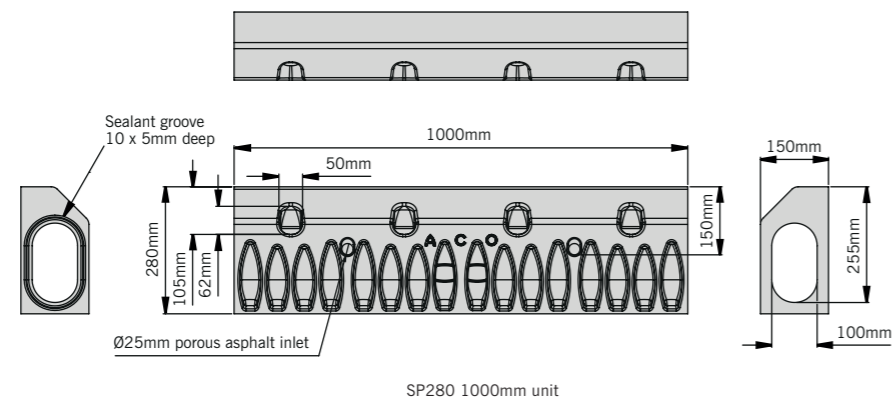

SP280 1000mm unit

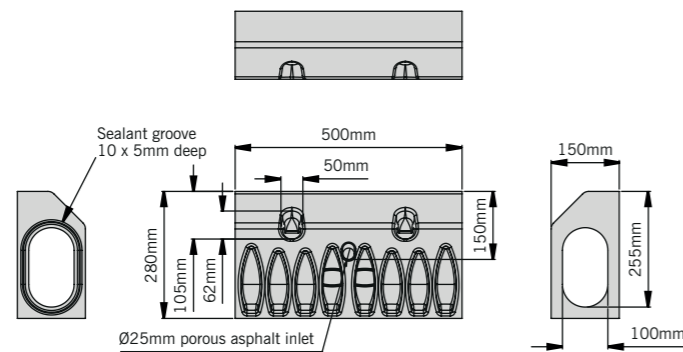

SP280 500mm unit

SP280 splayed rodding access unit

Product Code	Description	Length (mm)	Width Overall (mm)	Depth Overall (mm)	Invert depth (mm)	Weight (kg)
7937	KDSP280 access unit*	500	150/190	280	255	26.0

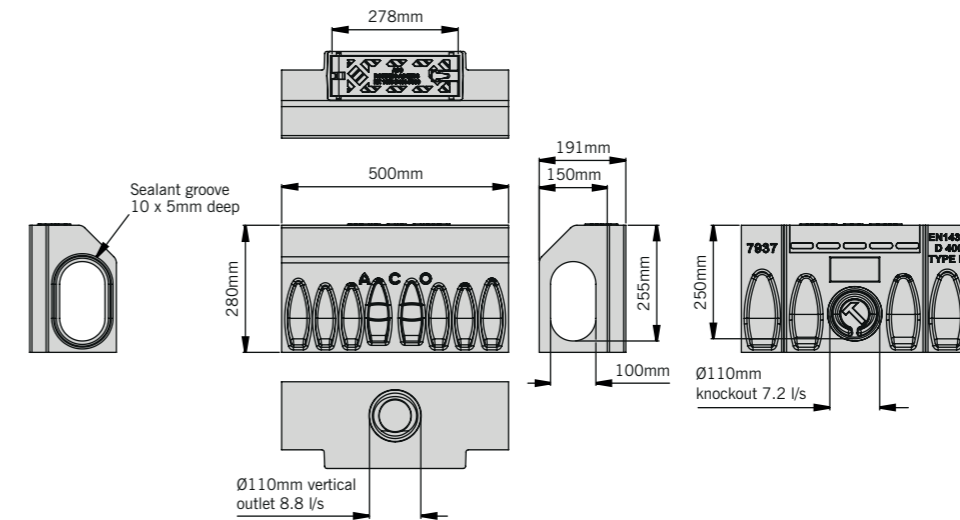

SP280 access unit

SP280 splayed drop kerb units

Product Code	Description	Length (mm)	Width Overall (mm)	Depth Overall (mm)	Invert depth (mm)	Weight (kg)
7938	KDSP280 LH drop kerb	1000	150	280	255	44.6
7939	KDSP280 RH drop kerb	1000	150	280	255	44.6

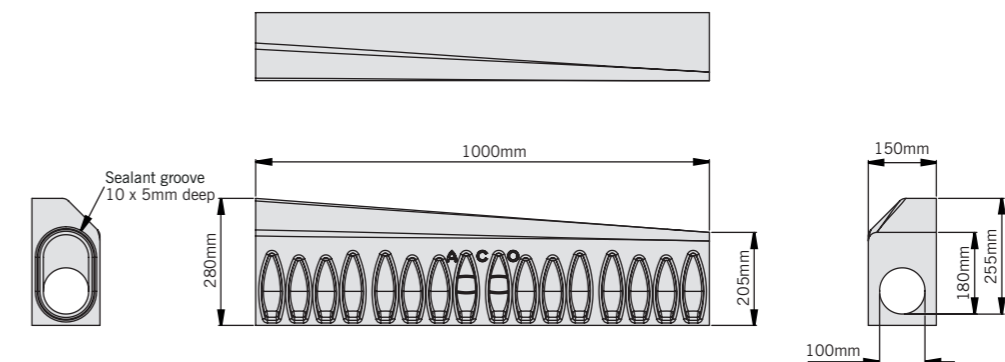

SP280 left hand drop kerb

[Click here](#) for installation details

[Click here](#) for details of product hydraulic capacities

These products are subject to weight and dimensional tolerances. The dimensions shown on this page are for guidance purposes only.

* Access unit cover can be hinged at either end and orientated to suit traffic direction.
Note: For details regarding the gully, foul air-traps and drain unions for use with this system please [click here](#).

ACO KerbDrain® SP280

[Click here](#) for details regarding gullies for use with this system

SP280 splayed centre stone unit with 25mm upstand

Product Code	Description	Length (mm)	Width Overall (mm)	Depth Overall (mm)	Invert depth (mm)	Weight (kg)
7965	KDSP280 centre stone	915	150	205	180	42.9

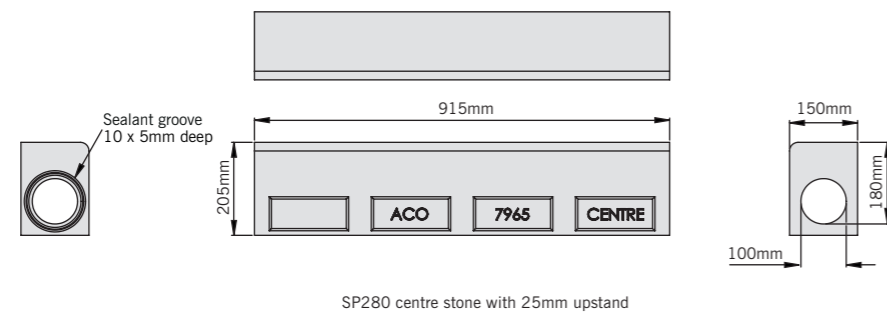

SP280 splayed perforated centre stone unit

Product Code	Description	Length (mm)	Width Overall (mm)	Depth Overall (mm)	Invert depth (mm)	Weight (kg)
4982	KDSP280 perforated centre stone	915	150	205	180	42.9

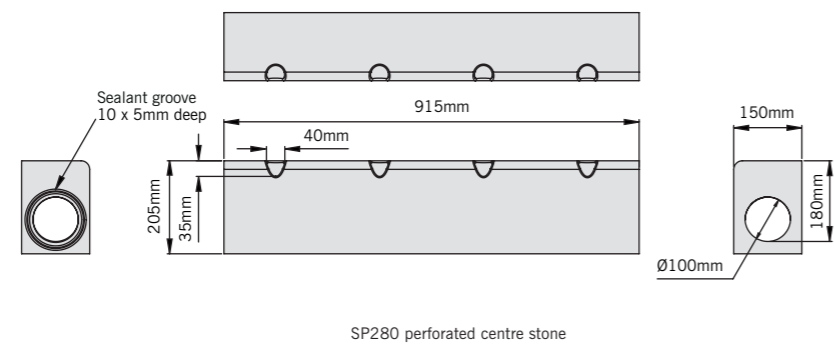

SP280 splayed transition units

Product Code	Description	Length (mm)	Width Overall (mm)	Depth Overall (mm)	Invert depth (mm)	Weight (kg)
7941	KDSP280 LH transition unit**	500	150	305/280	280/225	24.6
7940	KDSP280 RH transition unit**	500	150	280/305	280/225	24.6

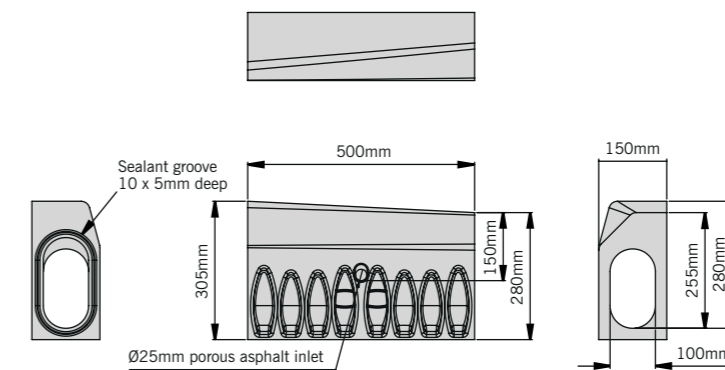

SP280 splayed end caps

Product Code	Description	Length (mm)	Width Overall (mm)	Depth Overall (mm)	Invert depth (mm)	Weight (kg)
4961	KDSP280 closing end cap	50	150	480	-	7.4
7942	KDSP280 LH inlet/outlet end cap†	50	150	280	255	3.4
7943	KDSP280 RH inlet/outlet end cap†	50	150	280	255	3.4

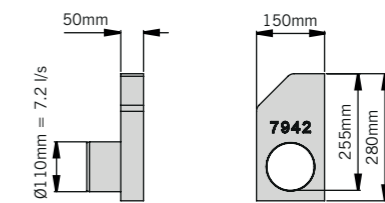
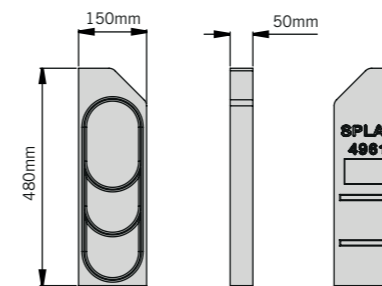

[Click here](#) for installation details

[Click here](#) for details of product hydraulic capacities

These products are subject to weight and dimensional tolerances. The dimensions shown on this page are for guidance purposes only.

** Transition units are designated LH or RH when viewed from carriageway. This unit allows connection between SP280 and HB305 for continuous drainage.

† Inlet / outlet end caps are designated LH or RH when viewed from carriageway.

Note: For details regarding the gully, foul air-traps and drain unions for use with this system please [click here](#).

ACO KerbDrain® SP380

[Click here](#) for details regarding gullies for use with this system

SP380 splayed kerb units

Product code	Description	Length (mm)	Width overall (mm)	Depth overall (mm)	Invert depth (mm)	Weight (kg)
4241	KDSP380 1000mm	1000	150	380	355	59.6
4240	KDSP380 500mm	500	150	380	355	29.0

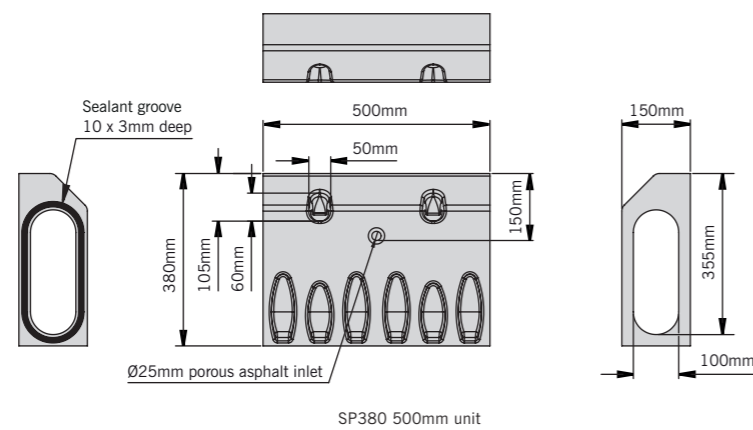
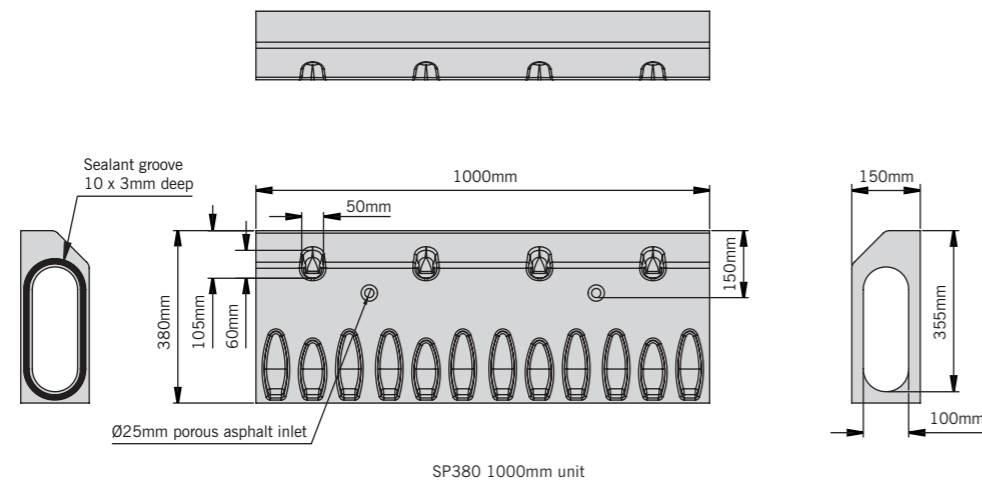

SP380 splayed rodding access units

Product code	Description	Length (mm)	Width overall (mm)	Depth overall (mm)	Invert depth (mm)	Weight (kg)
4242	KDSP380 access unit*	500	193	380	355	36.1

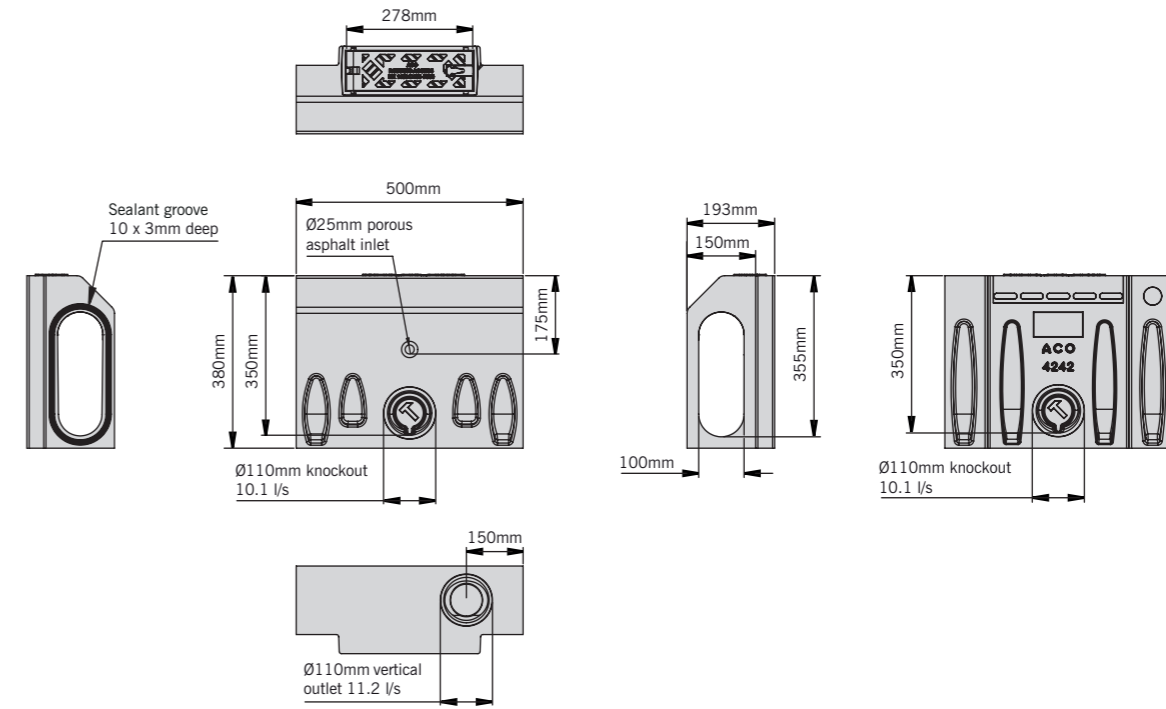

SP380 splayed drop kerb units

Product code	Description	Length (mm)	Width overall (mm)	Depth overall (mm)	Invert depth (mm)	Weight (kg)
4243	KDSP380 LH drop kerb	1000	150	380/305	355/280	59.5
4244	KDSP380 RH drop kerb	1000	150	380/305	355/280	59.5

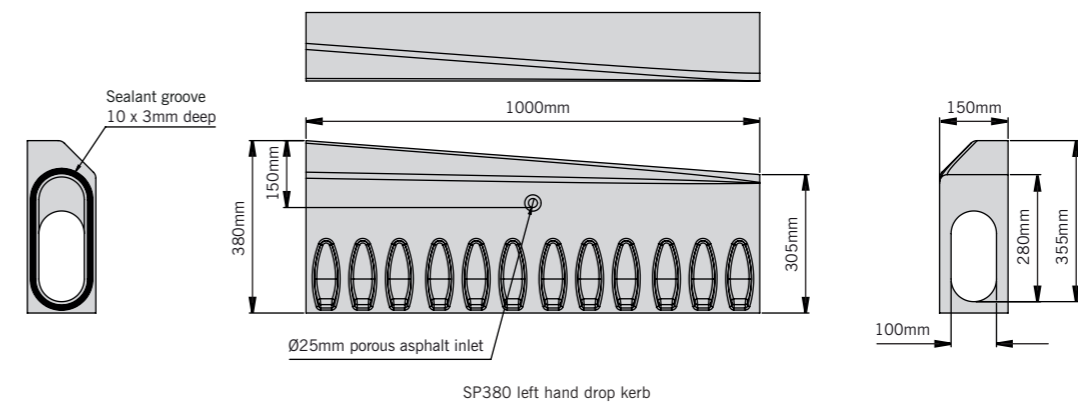

 [Click here](#) for installation details

 [Click here](#) for details of product hydraulic capacities

These products are subject to weight and dimensional tolerances. The dimensions shown on this page are for guidance purposes only.

* Access unit cover can be hinged at either end and orientated to suit traffic direction.
Note: For details regarding the gully, foul air-traps and drain unions for use with this system please [click here](#).

ACO KerbDrain® SP380

[Click here](#) for details regarding gullies for use with this system

SP380 splayed centre stone

Product code	Description	Length (mm)	Width overall (mm)	Depth overall (mm)	Invert depth (mm)	Weight (kg)
4236	KDSP380 centre stone	1000	150	305	280	60.1

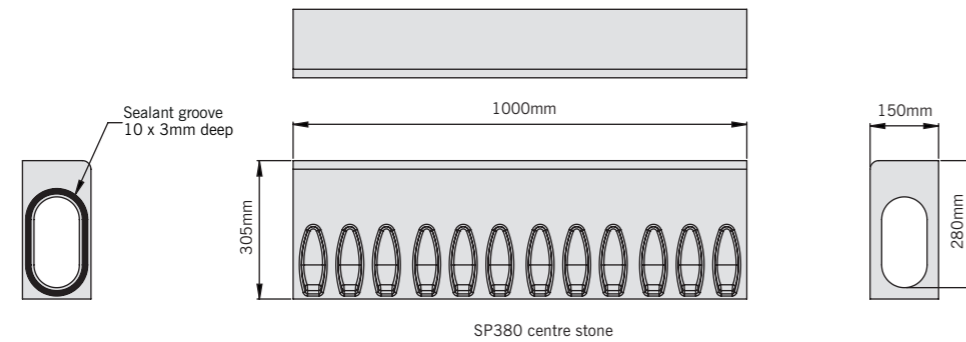

SP380 centre stone

SP380 splayed end caps

Product code	Description	Length (mm)	Width overall (mm)	Depth overall (mm)	Invert depth (mm)	Weight (kg)
4961	KDSP380 closing end cap	50	150	480	-	7.4
4247	KDSP380 LH inlet/outlet end cap†	50	150	380	355	5.1
4248	KDSP380 RH inlet/outlet end cap†	50	150	380	355	5.1

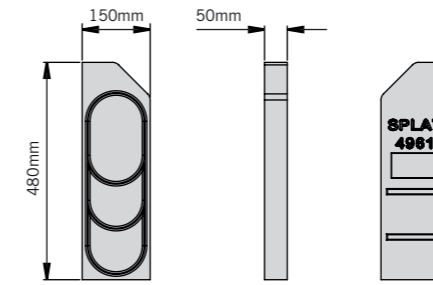

SP380 closing end cap

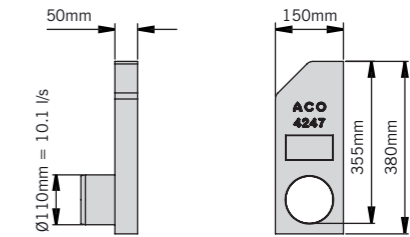

SP380 left hand inlet/outlet end cap

SP380 splayed transition units

Product code	Description	Length (mm)	Width overall (mm)	Depth overall (mm)	Invert depth (mm)	Weight (kg)
4245	KDSP380 LH transition unit**	500	150	405/380	380/355	31.0
4246	KDSP380 RH transition unit**	500	150	405/380	380/355	31.0

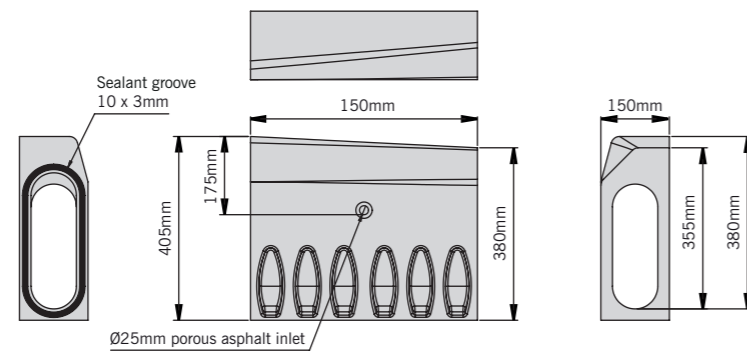

SP380 left hand transition unit



[Click here](#) for installation details



[Click here](#) for details of product hydraulic capacities

These products are subject to weight and dimensional tolerances. The dimensions shown on this page are for guidance purposes only.

**Transition units are designated LH or RH when viewed from carriageway. This unit allows connection between SP380 and HB405 for continuous drainage.

† Inlet / outlet end caps are designated LH or RH when viewed from carriageway.

Note: For details regarding the gully, foul air-traps and drain unions for use with this system please [click here](#).

ACO KerbDrain® SP480

[Click here](#) for details regarding gullies for use with this system

SP480 splayed kerb units

Product code	Description	Length (mm)	Width overall (mm)	Depth overall (mm)	Invert depth (mm)	Weight (kg)
4960	KDSP480 500mm	500	150	480	455	32.2

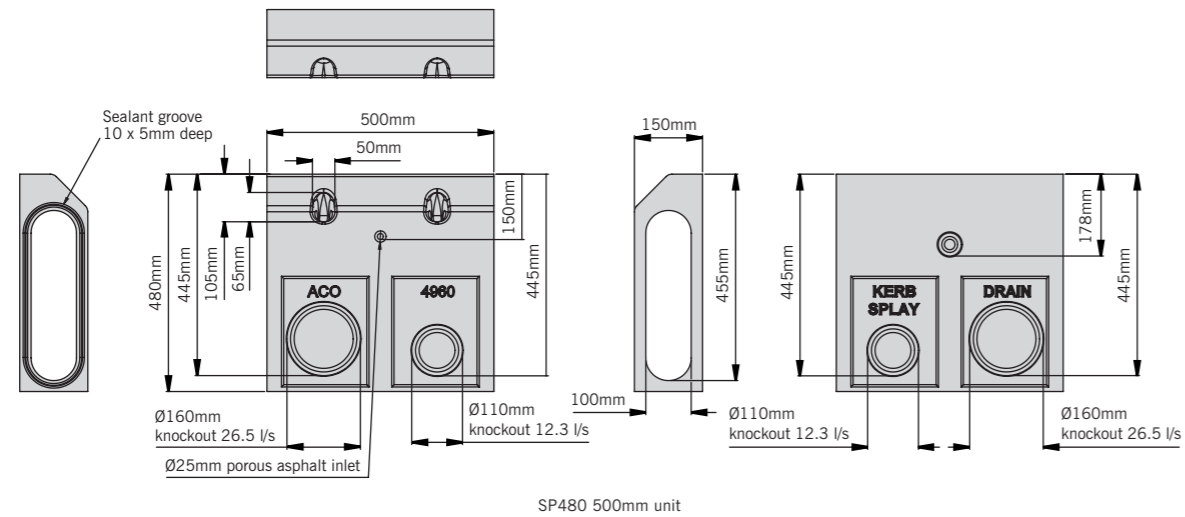

Access units for the ACO KerbDrain® SP480 system are provided by the splayed gully unit top assembly product code 4976. [Click here for details.](#)

SP480 splayed end caps

Product code	Description	Length (mm)	Width overall (mm)	Depth overall (mm)	Invert depth (mm)	Weight (kg)
4961	KDSP480 closing end cap	50	150	480	-	7.4
4962	KDSP480 LH inlet/outlet end cap†	197	150	480	455	5.8
4963	KDSP480 RH inlet/outlet end cap†	197	150	480	455	5.8

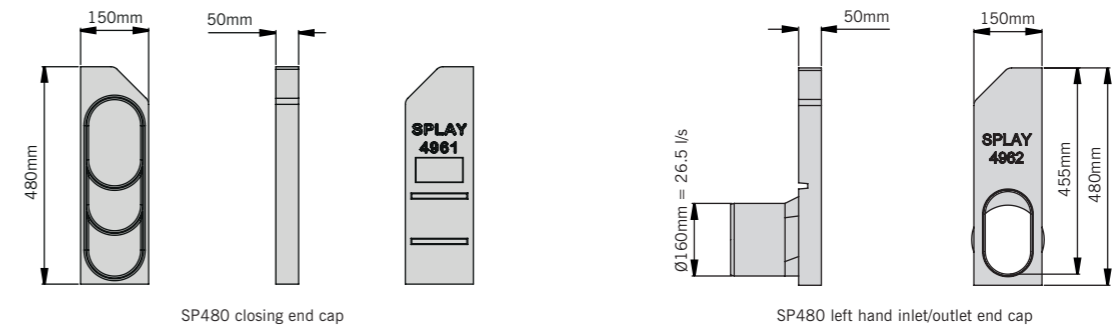

[Click here](#) for installation details



[Click here](#) for details of product hydraulic capacities

These products are subject to weight and dimensional tolerances. The dimensions shown on this page are for guidance purposes only.

† Inlet / outlet end caps are designated LH or RH when viewed from carriageway. Note: For details regarding the gully, foul air-traps and drain unions for use with this system please [click here](#).

ACO KerbDrain® splayed gully

ACO KerbDrain® splayed gully units provide the outfall connection of the system to traditional underground drainage or road gullies, management of silt, and access for maintenance and cleaning. The gully unit also provides fast and simple connection between any sizes of splayed unit within the ACO KerbDrain® range.

Gullies are supplied with a ductile iron cover and frame and a polymer concrete unit for channel connection. These two components form the top assembly for all ACO KerbDrain® gully options. The ductile iron cover of the top assembly is lockable and for improved safety to road users can be orientated to suit traffic direction.

The ACO KerbDrain® gully top assembly can be specified on its own or in conjunction with four polymer concrete base options which allow drainage designs to be optimised for silt and hydraulic capacity or outlet connection.

Available gully base options are shallow and deep units, deep unit with roddable foul air trap or Ø450mm road gully connector. All gully base units are provided with outlet connections for Ø160mm or Ø200mm pipe and supplied with a galvanised steel gully bucket. For full details please see table below.



ACO KerbDrain® splayed gully units

Product code	Description	Length (mm)	Width overall (mm)	Depth overall (mm)	Invert depth (mm)	Invert type	Weight (kg)
4976	Top assembly KDSPG	500	390	520	-	-	73.0
4977	Top and shallow base assembly KDSP610	500	390	870	845	-	100.9
4978	Top and deep base assembly KDSP611	500	390	1025	750/955	-	109.7
4979	Top and roddable deep base assembly KDSP612RE	500	390	1025	750/780	-	119.9
4980	Top and road gully connector Ø450mm KDSP615	500	390	545	-	-	81.5
1616	Gully bucket	395	250	330	-	-	4.7

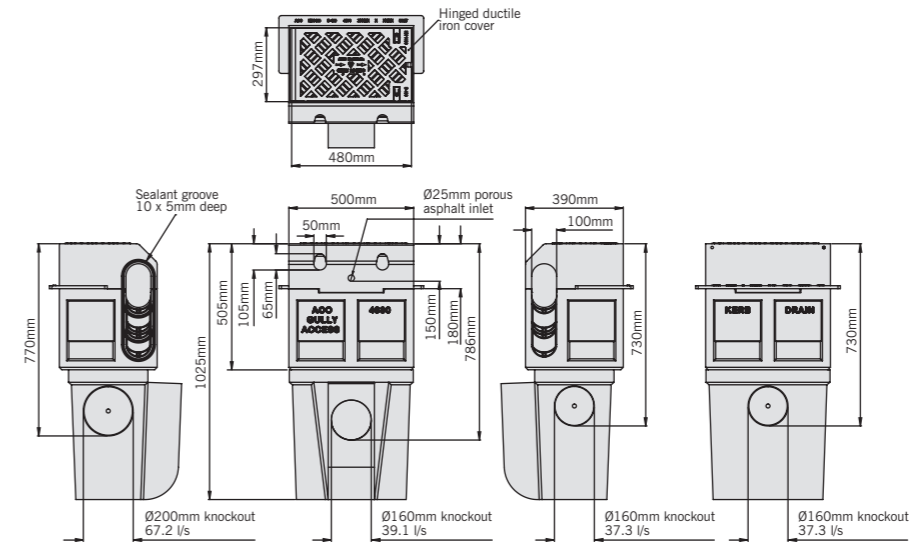

Top and roddable deep base assembly KDSP612RE

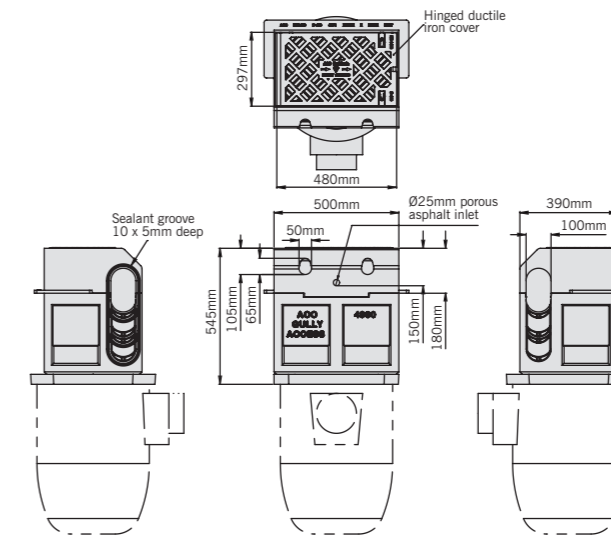

Top and road gully connector KDSP615

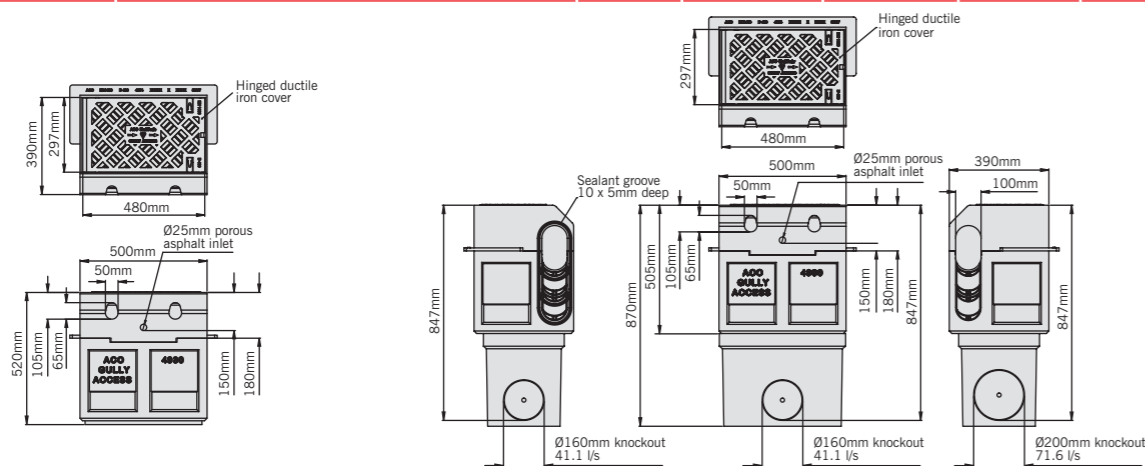

Top assembly KDSPG

Top and shallow base assembly KDSP610

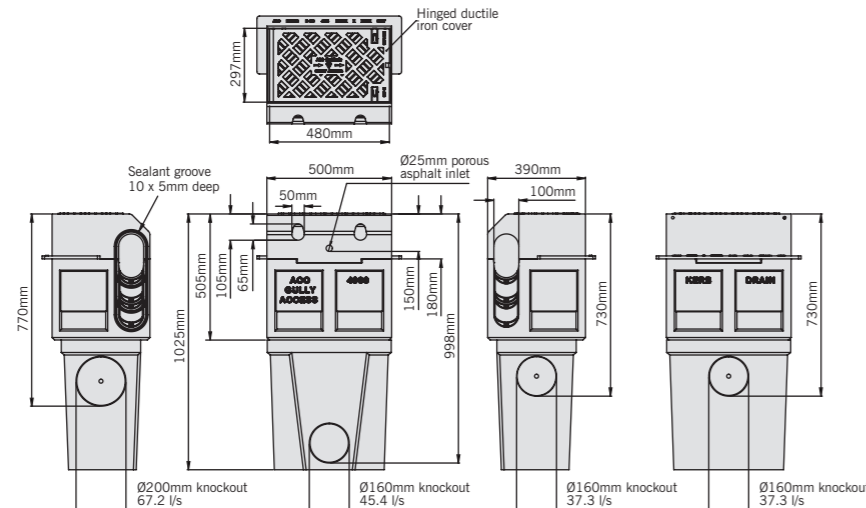

Top and deep base assembly KDSP611

Drain unions and foul air-trap

Product code	Description	Length (mm)	Width overall (mm)	Depth overall (mm)	Invert depth (mm)	Invert type	Weight (kg)
0056	820 Drain union PVC-U Ø110mm	100	110	-	-	-	0.1
0058	822 Drain union PVC-U Ø160mm	150	160	-	-	-	0.5
2723	823 Drain union PVC-U Ø200mm	200	200	-	-	-	0.6
2638	922 Foul roddable air trap PVC-U Ø160mm	-	160	-	-	-	1.9

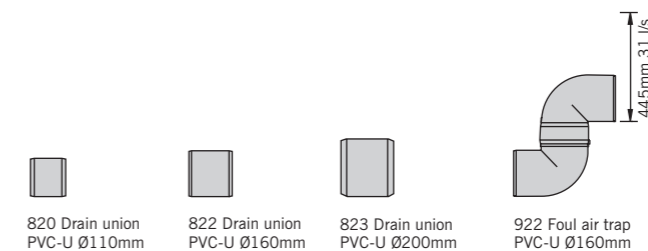

These products are subject to weight and dimensional tolerances. The dimensions shown on this page are for guidance purposes only.

Designing a combined kerb drainage system

ACO Water Management uses in-house software, verified by experimental testing, for hydraulic design of steady non-uniform flow in channels. This software uses the "spatially varied flow" differential equation to evaluate the backwater curve profile of the water within the channels.

The software provides the correct analysis of flow in a channel accepting flow all along its length, and enables accurate calculation of flow in constant and stepped channels. The program also allows the inclusion of end inflow and point inflows into the channel.

Correct analysis using ACO Water Management Hydro software will give results that are dependent on the length of channel to the outfall. The hydraulic performance tables used in this and other ACO Water Management brochures are produced using this software.

The following chart illustrates the particular case of a length to outfall of 50m, and shows that there is still plenty of capacity in a drainage channel laid at zero slope.

ACO Water Management Design Services Team

For detailed designs using the ACO Hydro software, please contact the ACO Water Management Design Services Team. The team should also be consulted for advice where the inflow is not uniformly distributed along the channel.

The hydraulic performance tables have been produced from the ACO Hydro software to facilitate a quick manual design method for the determination of the drainage requirements.

The columns of drainage catchment area ($A \text{ m}^2$) are based on a rainfall intensity of 50mm/h, but can be adapted for use at any rainfall intensity. The columns of maximum flow rate ($Q \text{ l/s}$) and maximum lateral inflow ($q \text{ l/s/m}$) can be used at any rainfall intensity.

ACO Water Management Design Services Team

Tel: 01462 816666
Email technical@aco.co.uk

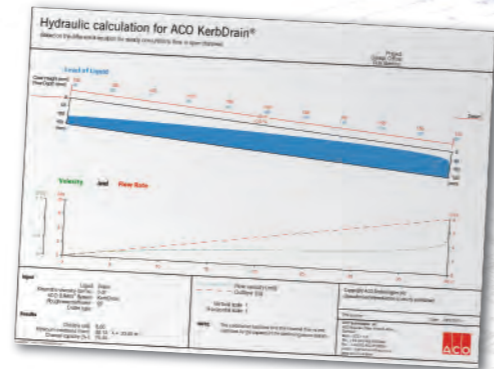
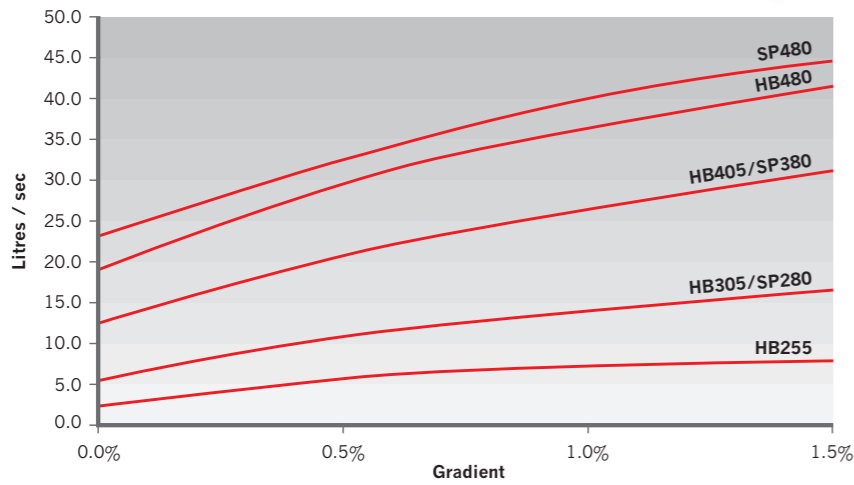

ACO Hydraulic Design Software

Register online for our free, secure online design software:

- ▶ All designs are securely stored and easily accessed online
- ▶ Data always up-to-date
- ▶ Proven calculation methodology - more accurate and efficient designs
- ▶ Flexible catchment design
- ▶ Integrated rainfall data
- ▶ Automated product optimisation
- ▶ PDF summary documents

Register Now - It's Free
www.acodesign.co.uk

[Click here](#) for details of product hydraulic capacities



It should be noted that other methods will not give the correct results for channel drainage systems. In particular the use of equations of steady uniform flow, such as Manning's equation, is totally inappropriate for channel drainage design. They will not work at all with level channels and will give grossly inaccurate results at shallow gradients.

Design example

For a design of ACO KerbDrain® HB305, assume the following figures:

D = 7.3m (depth of catchment area)

L = 80m (length of run = length of catchment)

i = 86mm/h (design rainfall intensity)
Ground slope = 0%

The capacity of the proposed ACO KerbDrain® HB305 channel can be determined from the tables in this brochure in any one of three ways. Using the catchment area is particularly easy when the UK default rainfall intensity of 50mm/h is used for design (but can be used at other rainfall intensities as in the example below). Using the total flowrate Q or the lateral inflow q the capacity can be read straight off the tables at any rainfall intensity.

 [Click here](#) for details of product hydraulic capacities

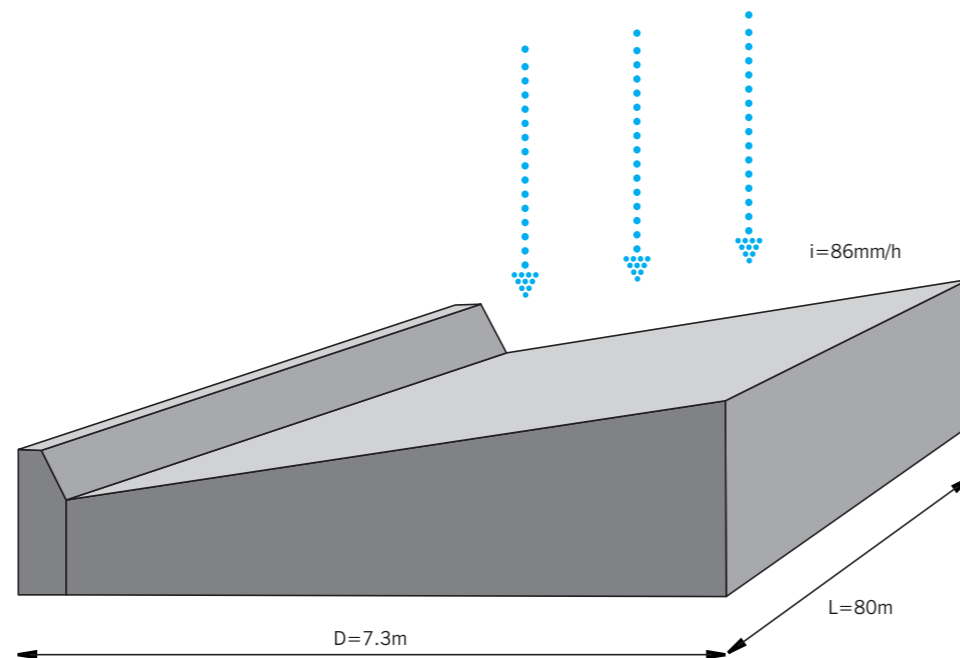

GUIDANCE NOTES

1. Determine the area

$$\text{Area} = L \times D = 80 \times 7.3 = 584 \text{ m}^2$$

The tables in the respective product sections give the maximum area that can be drained. However the tables use the standard UK default rainfall intensity of 50mm/h, and this design requires a higher design rainfall of 86mm/h.

So in order to use the tables to determine the maximum area that can be drained, increase the effective area to, in this case, $584 \times 86/50 = 1004\text{m}^2$.

From the tables for ACO KerbDrain® 305 on [page 27](#), for a slope of 0% it can be seen that an 80m length can not drain the required 1004m^2 . (Max area from the table is 795m^2).

From the same table it can be determined that a 60m length could drain the 7.3m wide carriageway. $60 \times 7.3 \times 86/50 = 753\text{m}^2$ and the table for 60m length shows 864m^2 , so if an outlet can be positioned at 60m it will be satisfactory.

Alternatively, for ACO KerbDrain® that can run the whole 80m length, see the table for ACO KerbDrain® HB480 on [page 27](#). The table shows that an 80m run of HB480 can easily drain 1004m^2 (actually it could drain 1196m^2).

2. Determine the total flow in the channel (Q)

The total flow $Q = \text{area} \times \text{rainfall intensity}$ (and where rainfall intensity is in mm/h, divide by 3600 to adjust the units from hours to seconds).

$$Q = 80 \times 7.3 \times 86 / 3600 = 13.95 \text{ l/s}$$

Again we see from the table that the 80m run of HB305 can not carry the flow (max flow rate from the table is 11.0 l/s). Also we can again determine that the 60m run length would work. $(60 \times 7.3 \times 86/3600 = 10.5 \text{ l/s})$, and the table for 60m gives a maximum capacity of 12.0 l/s.

We can also see from the HB480 table that 80m of HB480 could carry the whole flow from 80m.

3. Determine the lateral inflow rate (q)

Dividing the total flow by the total channel length gives the rate of lateral inflow into the channel, in l/s per metre run of channel.

$$q = Q / L$$

$$q = 13.95 / 80 = 0.174 \text{ l/s.m}$$

From the table for HB305, it can be seen that a 60m length can take 0.20 l/s.m and a 70m length can take 0.16 l/s.m. Interpolating between these two data points shows that the actual lateral inflow of 0.174 could be carried by a maximum length of 66.5m of HB305.

Drop kerbs and centre stones

Drop kerbs will act as a throttle in the line of channel drainage. Where possible, site an outlet upstream of these features. Where not possible, check the maximum flowrate that the centre stone has to carry and look up the capacity tables for the centre stone. Note that if the capacity is exceeded, what will happen is that the centre stone will surcharge, and in extreme storms part of the total flow might bypass the centre stone and run in the road gutter until it can re-enter the channel downstream of the centre stone.

Outlets

Check that the proposed outlet has sufficient hydraulic capacity for the flow rate. The capacity of the gullies, outlet end caps and knockouts from channel units are all provided in product parts tables in this brochure.

ACO KerbDrain® HB hydraulic performance tables

Hydraulic capacities

The tables opposite shows the maximum capacity of the unit, assuming uniform lateral inflow to the unit. The capacity will depend on the length of unit to the outlet and on any slope along the unit.

Q (l/s) is the maximum total flow that the channel can carry.

q (l/s/m) is the maximum possible lateral inflow.

A (m²) is the maximum area that can be drained and will depend on the design rainfall intensity chosen. The tabulated areas are for a rainfall intensity of 50mm/h (0.014 l/s/m²).

At other rainfall intensities, the area can be determined by proportion, e.g. at 75mm/h, the maximum area drained will be the tabulated area x 50/75.

ACO Water Management Design Services Team

Please contact the ACO Water Management Design Services Team on 01462 816666 for advice on channels with non-uniform inflow, or channels receiving point inflows at the end or at intermediate locations. The ACO Water Management Design Services Team will be pleased to assist with any technical queries, scheme designs or parts schedules.

Designing a drainage system

[Click here](#) for a for an example design method which will help determine your drainage requirements.

This example will enable you to use the hydraulic performance tables on this page.

ACO KerbDrain® HB255 kerb units

Length to Outlet (m)	0%			0.5%			1%			1.5%		
	Q (l/s)	q (l/s/m)	A (m ²)	Q (l/s)	q (l/s/m)	A (m ²)	Q (l/s)	q (l/s/m)	A (m ²)	Q (l/s)	q (l/s/m)	A (m ²)
10	3.2	0.32	230	4.6	0.46	331	5.5	0.55	396	6.3	0.63	454
20	2.9	0.14	206	4.9	0.25	353	6.2	0.31	446	7.1	0.35	508
30	2.6	0.09	187	5.1	0.17	367	6.7	0.22	480	7.6	0.25	549
40	2.4	0.06	171	5.2	0.13	374	6.8	0.17	490	7.8	0.20	564
50	2.1	0.04	154	5.3	0.11	378	6.8	0.14	490	7.9	0.16	569
60	2.1	0.03	148	5.2	0.09	374	6.7	0.11	485	7.9	0.13	566
70	2.0	0.03	142	5.0	0.07	359	6.7	0.10	479	7.8	0.11	560
80	1.9	0.02	140	4.8	0.06	346	6.6	0.08	474	7.7	0.10	552
90	1.9	0.02	137	4.6	0.05	332	6.4	0.07	464	7.6	0.08	547
100	1.9	0.02	137	4.4	0.04	317	6.3	0.06	454	7.5	0.08	540

ACO KerbDrain® HB255 centre stone units (end flow)

Length to Outlet (m)	0%		0.5%		1%		1.5%	
	Q (l/s)	A (m ²)	Q (l/s)	A (m ²)	Q (l/s)	A (m ²)	Q (l/s)	A (m ²)
10	1.2	86	2.5	180	3.7	266	4.6	331
20	0.9	65	2.5	180	3.7	266	4.6	331
30	0.8	55	2.5	180	3.7	266	4.6	331
40	0.7	50	2.5	180	3.7	266	4.6	331
50	0.7	50	2.5	180	3.7	266	4.6	331

ACO KerbDrain® HB305 kerb units

Length to Outlet (m)	0%			0.5%			1%			1.5%		
	Q (l/s)	q (l/s/m)	A (m ²)	Q (l/s)	q (l/s/m)	A (m ²)	Q (l/s)	q (l/s/m)	A (m ²)	Q (l/s)	q (l/s/m)	A (m ²)
10	7.1	0.71	509	9.5	0.95	684	11.1	1.11	799	12.5	1.25	900
20	6.5	0.33	469	10.1	0.51	731	12.2	0.61	877	14.0	0.70	1011
30	6.1	0.20	437	10.6	0.35	761	13.0	0.43	935	15.1	0.50	1090
40	5.7	0.14	412	10.8	0.27	778	13.6	0.34	979	15.8	0.40	1140
50	5.4	0.11	386	10.9	0.22	786	13.9	0.28	1000	16.3	0.33	1172
60	5.2	0.09	371	11.0	0.18	794	14.2	0.24	1022	16.7	0.28	1201
70	4.9	0.07	354	11.1	0.16	797	14.3	0.20	1033	16.8	0.24	1211
80	4.7	0.06	340	11.1	0.14	800	14.5	0.18	1044	17.0	0.21	1222
90	4.6	0.05	330	11.2	0.12	803	14.7	0.16	1055	17.1	0.19	1233
100	4.5	0.05	324	11.2	0.11	806	14.8	0.15	1066	17.3	0.17	1243

ACO KerbDrain® HB305 centre stone units (end flow)

Length to Outlet (m)	0%		0.5%		1%	
	Q (l/s)	A (m ²)	Q (l/s)	A (m ²)	Q (l/s)	A (m ²)
10	3.0	216	4.2	302	6.0	432
20	2.3	166	4.2	302	6.0	432
30	1.9	139	4.2	302	6.0	432
40	1.7	122	4.2	302	6.0	432
50	1.6	115	4.2	302	6.0	432

ACO KerbDrain® HB405 kerb units

Length to Outlet (m)	0%			0.5%			1%			1.5%		
	Q (l/s)	q (l/s/m)	A (m ²)	Q (l/s)	q (l/s/m)	A (m ²)	Q (l/s)	q (l/s/m)	A (m ²)	Q (l/s)	q (l/s/m)	A (m ²)
10	16.0	1.60	1152	19.5	1.95	1404	22.0	2.20	1584	24.4	2.44	1757
20	14.6	0.73	1053	20.3	1.01	1461	23.8	1.19	1715	27.1	1.35	1949
30	13.8	0.46	994	20.8	0.69	1495	25.1	0.84	1804	28.5	0.95	2052
40	13.1	0.33	940	21.0	0.52	1509	25.9	0.65	1862	29.7	0.74	2135
50	12.4	0.25	894	20.9	0.42	1508	26.2	0.52	1889	30.6	0.61	2200
60	12.0	0.20	864	21.1	0.35	1522	26.7	0.44	1922	31.2	0.52	2249
70	11.3	0.16	817	21.2	0.30	1528	26.9	0.38	1938	31.8	0.45	2292
80	11.0	0.14	795	21.3	0.27	1532	27.2	0.34	1958	32.0	0.40	2304
90	10.5	0.12	757	21.3	0.24	1537	27.4	0.30	1972	32.1	0.36	2313
100	10.2	0.10	734	21.4	0.21	1541	27.5	0.28	1982	32.2	0.32	2321
120	9.6	0.08	691	21.5	0.18	1548	27.8	0.23	2000	32.4	0.27	2333
140	9.2	0.07	665	21.6	0.15	1552	28.0	0.20	2016	32.4	0.23	2335

ACO KerbDrain® HB405 centre stone units (end flow)

Length to Outlet (m)	0%		0.5%		1%		1.5%	
	Q (l/s)	A (m ²)	Q (l/s)	A (m ²)	Q (l/s)	A (m ²)	Q (l/s)	A (m ²)
10	864	216	16.5	1188	21.5	1548	25.0	1800
20	684	166	15.9	1143	21.0	1512	25.0	1800
30	576	139	15.7	1130	21.0	1512	25.0	1800
40	504	122	15.6	1123	21.0	1512	25.0	1800
50	468	115	15.6	1120	21.0	1512	25.0	1800

ACO KerbDrain® HB480 kerb units

Length to Outlet (m)	0%			0.5%			1%			1.5%		
	Q (l/s)	q (l/s/m)	A (m ²)	Q (l/s)	q (l/s/m)	A (m ²)	Q (l/s)	q (l/s/m)	A (m ²)	Q (l/s)	q (l/s/m)	A (m ²)
10	24.0	2.40	1728	28.3	2.83	2038	31.6	3.16	2275	34.3	3.43	2470
20	22.0	1.10	1584	28.8	1.44	2074	33.6	1.68	2419	37.8	1.89	2722
30	20.7	0.69	1487	29.0	0.97	2090	34.7	1.16	2500	39.6	1.32	2850
40	19.7	0.49	1421	29.3	0.73	2112	36.0	0.90	2591	41.0	1.02	2949
50	18.9	0.38	1360	29.4	0.59	2116	36.4	0.73	2624	41.6	0.83	2995
60	18.0	0.30	1296	29.7	0.50	2138	36.8	0.61	2652	42.4	0.71	3050
70	17.2	0.25	1240	29.7	0.42	2139	37.2	0.53	2681	43.0	0.61	3095
80	16.6	0.21	1196	29.7	0.37	2140	37.3	0.47	2687	43.2	0.54	3113
90	16.0	0.18	1154	29.7	0.33	2139	37.6	0.42	2709	43.4	0.48	3128
100	15.6	0.16	1120	29.7	0.30	2138	37.7	0.38	2713	43.8	0.44	3152
120	14.8	0.12	1062	29.7	0.25	2136	37.9	0.32	2726	44.3	0.37	3187
140	14.0	0.10	1009	29.6	0.21	2134	38.1	0.27	2742	44.7	0.32	3216
160	13.4	0.08	964	29.6	0.19	2131	38.2	0.24	2750	45.0	0.28	3237
180	12.8	0.07	923	29.4	0.16	2115	38.3	0.21	2758	45.0	0.25	3240
200	12.4	0.06	893	29.2	0.15	2100	38.4	0.19	2765	45.0	0.23	3241

ACO KerbDrain® HB480 centre stone units (end flow)

Length to Outlet (m)	0%		0.5%		1%		1.5%	
	Q (l/s)	A (m ²)	Q (l/s)	A (m ²)	Q (l/s)	A (m ²)	Q (l/s)	A (m ²)
10	19.0	1368	25.0	1800	31.0	2232	37.0	2664
20	15.1	1085	23.0	1656	30.0	2160	37.0	2664
30	13.0	936	22.0	1584	30.0	2160	37.0	2664
40	11.5	828	22.0	1584	30.0	2160	37.0	2664
50	10.8	778	22.0	1584	30.0	2160	37.0	2664

ACO KerbDrain® SP hydraulic performance tables

Hydraulic capacities

The tables opposite shows the maximum capacity of the unit, assuming uniform lateral inflow to the unit. The capacity will depend on the length of unit to the outlet and on any slope along the unit.

Q (l/s) is the maximum total flow that the channel can carry.

q (l/s/m) is the maximum possible lateral inflow.

A (m²) is the maximum area that can be drained and will depend on the design rainfall intensity chosen. The tabulated areas are for a rainfall intensity of 50mm/h (0.014 l/s/m²).

At other rainfall intensities, the area can be determined by proportion, e.g. at 75mm/h, the maximum area drained will be the tabulated area x 50/75.

ACO Water Management Design Services Team

Please contact the ACO Water Management Design Services Team on 01462 816666 for advice on channels with non-uniform inflow, or channels receiving point inflows at the end or at intermediate locations. The ACO Water Management Design Services Team will be pleased to assist with any technical queries, scheme designs or parts schedules.

Designing a drainage system

[Click here](#) for a for an example design method which will help determine your drainage requirements.

This example will enable you to use the hydraulic performance tables on this page.

ACO KerbDrain® SP280 kerb units

Length to Outlet (m)	0%			0.5%			1%			1.5%		
	Q (l/s)	q (l/s/m)	A (m ²)	Q (l/s)	q (l/s/m)	A (m ²)	Q (l/s)	q (l/s/m)	A (m ²)	Q (l/s)	q (l/s/m)	A (m ²)
10	7.1	0.71	509	9.5	0.95	684	11.1	1.11	799	12.5	1.25	900
20	6.5	0.33	469	10.1	0.51	731	12.2	0.61	877	14.0	0.70	1011
30	6.1	0.20	437	10.6	0.35	761	13.0	0.43	935	15.1	0.50	1090
40	5.7	0.14	412	10.8	0.27	778	13.6	0.34	979	15.8	0.40	1140
50	5.4	0.11	386	10.9	0.22	786	13.9	0.28	1000	16.3	0.33	1172
60	5.2	0.09	371	11.0	0.18	794	14.2	0.24	1022	16.7	0.28	1201
70	4.9	0.07	354	11.1	0.16	797	14.3	0.20	1033	16.8	0.24	1211
80	4.7	0.06	340	11.1	0.14	800	14.5	0.18	1044	17.0	0.21	1222
90	4.6	0.05	330	11.2	0.12	803	14.7	0.16	1055	17.1	0.19	1233
100	4.5	0.05	324	11.2	0.11	806	14.8	0.15	1066	17.3	0.17	1243

ACO KerbDrain® SP280 centre stone units (end flow)

Length to Outlet (m)	0%		0.5%		1%		1.5%	
	Q (l/s)	A (m ²)	Q (l/s)	A (m ²)	Q (l/s)	A (m ²)	Q (l/s)	A (m ²)
10	3.0	216	4.2	302	6.0	432	7.4	533
20	2.3	166	4.2	302	6.0	432	7.4	533
30	1.9	139	4.2	302	6.0	432	7.4	533
40	1.7	122	4.2	302	6.0	432	7.4	533
50	1.6	115	4.2	302	6.0	432	7.4	533

ACO KerbDrain® SP380 kerb units

Length to Outlet (m)	0%			0.5%			1%			1.5%		
	Q (l/s)	q (l/s/m)	A (m ²)	Q (l/s)	q (l/s/m)	A (m ²)	Q (l/s)	q (l/s/m)	A (m ²)	Q (l/s)	q (l/s/m)	A (m ²)
10	16.0	1.60	1152	19.5	1.95	1404	22.0	2.20	1584	24.4	2.44	1757
20	14.6	0.73	1053	20.3	1.01	1461	23.8	1.19	1715	27.1	1.35	1949
30	13.8	0.46	994	20.8	0.69	1495	25.1	0.84	1804	28.5	0.95	2052
40	13.1	0.33	940	21.0	0.52	1509	25.9	0.65	1862	29.7	0.74	2135
50	12.4	0.25	894	20.9	0.42	1508	26.2	0.52	1889	30.6	0.61	2200
60	12.0	0.20	864	21.1	0.35	1522	26.7	0.44	1922	31.2	0.52	2249
70	11.3	0.16	817	21.2	0.30	1528	26.9	0.38	1938	31.8	0.45	2292
80	11.0	0.14	795	21.3	0.27	1532	27.2	0.34	1958	32.0	0.40	2304
90	10.5	0.12	757	21.3	0.24	1537	27.4	0.30	1972	32.1	0.36	2313
100	10.2	0.10	734	21.4	0.21	1541	27.5	0.28	1982	32.2	0.32	2321
120	9.6	0.08	691	21.5	0.18	1548	27.8	0.23	2000	32.4	0.27	2333
140	9.2	0.07	665	21.6	0.15	1552	28.0	0.20	2016	32.4	0.23	2335

ACO KerbDrain® SP380 centre stone units (end flow)

Length to Outlet (m)	0%		0.5%		1%		1.5%	
	Q (l/s)	A (m ²)	Q (l/s)	A (m ²)	Q (l/s)	A (m ²)	Q (l/s)	A (m ²)
10	12.0	864	16.5	1188	21.5	1548	25.0	1800
20	9.5	684	15.9	1143	21.0	1512	25.0	1800
30	8.0	576	15.7	1130	21.0	1512	25.0	1800
40	7.0	504	15.6	1123	21.0	1512	25.0	1800
50	6.5	468	15.6	1120	21.0	1512	25.0	1800

ACO KerbDrain® SP480 hydraulic performance tables

Length to Outlet (m)	0%			0.5%			1%			1.5%		
	Q (l/s)	q (l/s/m)	A (m ²)	Q (l/s)	q (l/s/m)	A (m ²)	Q (l/s)	q (l/s/m)	A (m ²)	Q (l/s)	q (l/s/m)	A (m ²)
10	27.0	2.70	1944	31.4	3.14	2261	35.0	3.50	2520	38.3	3.83	2758
20	25.0	1.25	1800	32.0	1.60	2304	37.0	1.85	2664	41.4	2.07	2981
30	23.2	0.77	1670	32.4	1.08	2329	38.2	1.27	2748	43.3	1.44	3120
40	21.6	0.54	1557	32.5	0.81	2340	39.0	0.97	2807	45.3	1.13	3260
50	20.7	0.41	1490	32.6	0.65	2345	39.7	0.79	2860	46.4	0.93	3343
60	20.1	0.34	1447	32.6	0.54	2348	40.2	0.67	2894	46.9	0.78	3378
70	19.3	0.28	1391	32.6	0.47	2348	40.8	0.58	2937	47.4	0.68	3412
80	18.8	0.24	1356	32.6	0.41	2348	41.1	0.51	2957	47.6	0.60	3429
90	18.2	0.20	1307	32.6	0.36	2345	41.5	0.46	2990	48.0	0.53	3453
100	17.8	0.18	1282	32.5	0.33	2341	41.7	0.42	3003	48.2	0.48	3467
120	16.9	0.14	1218	32.4	0.27	2334	41.9	0.35	3019	48.7	0.41	3505
140	16.1	0.12	1159	32.3	0.23	2328	42.0	0.30	3024	49.2	0.35	3540
160	15.2	0.10	1096	32.3	0.20	2324	41.9	0.26	3019	49.8	0.31	3589
180	14.5	0.08	1047	32.2	0.18	2321	41.8	0.23	3011	50.4	0.28	3629
200	14.0	0.07	1008	32.2	0.16	2318	41.8	0.21	3010	50.8	0.25	3658

Installation detail

ACO KERBDRAIN® HALF BATTERED UNITS

Block pavement

- Option 1**
Block bedded using mortar as note 2.
- Option 2**
Concrete surround up to finished level. See note 2.

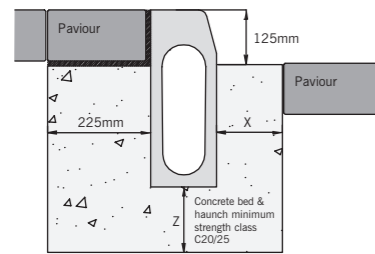

Grass or asphalt pavement

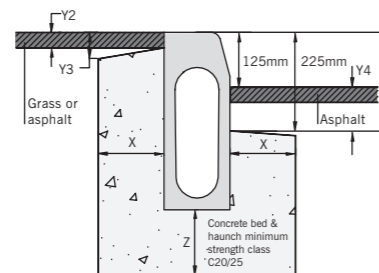

Concrete pavement

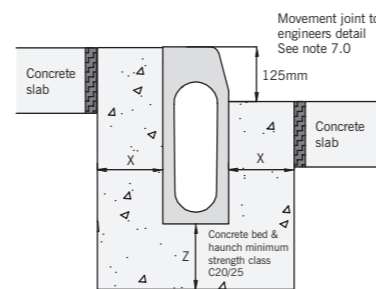

1.0 Ground conditions:

The customer should ensure that the minimum dimensions shown are suitable for the existing ground conditions. Engineering advice may be necessary.

2.0 Block pavements:

The channels must be supported laterally and therefore blocks must be restrained from movement by bedding securely, e.g. by using an Epoxy or Polymer Modified Mortar for bed and perpendicular joints (for example RONAFIX Mortar Mix C or similar). Engineering advice may be required. Alternatively, extend concrete haunch up to finished paving level (as option 2 above).

3.0 Surface cracks:

Alternate crack control and movement joints transversely within bed and haunch may reduce unsightly surface cracking. Engineering advice may be required.

4.0 Joint sealant:

Where ACO channel joints and fittings are to be sealed (where used in foul water applications or where impermeability is required, for example), use a suitable proprietary sealant such as a one part polyurethane together with cleaner and/or primer as specified by the sealant manufacturer.

Fill the sealing groove with a generous bead of sealant, sufficient to ensure the joint is fully sealed when the channel units are pushed together.

5.0 Accessories:

Installation details for ACO KerbDrain® accessories are available on request.

6.0 Load Class:

See note 8.0 for minimum concrete haunch dimensions for BS EN 1433 Load Class D 400. If the requirement is for Load Class C 250 or less, the front haunch may be omitted.

7.0 General installation notes:

See drawing E1-E01-003-3 for general notes on installation. Where installed against concrete roadways, note particularly the requirement for movement joints to allow for thermal expansion of slabs.

Best practice and workmanship

ACO can give guidance with respect to the most suitable methods of installation for each of the products in the ACO KerbDrain® range. ACO KerbDrain® should be installed using acceptable levels of workmanship and according to the National Code of Practice (UK: BS8000: Part 14: 1989) in keeping with EN 1433:2002 (Drainage channels for vehicular and pedestrian areas).

Detailed installation statements and methodologies will vary for all sites as each will have different aspects deserving particular consideration, consequently the relevant approvals should be sought from the consulting engineer and/or the installer.

ACO KERBDRAIN® SPLAYED UNITS

Block pavement

- Option 1**
Block bedded using mortar as note 2.
- Option 2**
Concrete surround up to finished level. See note 2.

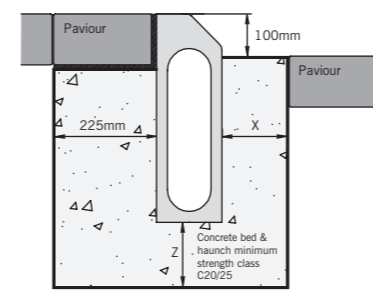

Grass or asphalt pavement

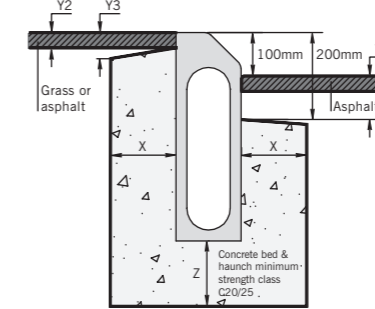

Concrete pavement

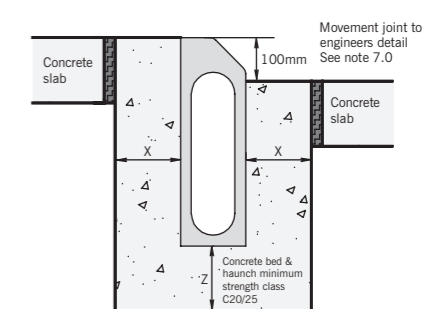

8.0 Concrete surround dimensions:

Dimension	Load Class	
	A 15 – C 250	D 400*
X	Min 150mm	Min 150mm
Z	Min 150mm	Min 150mm
Y2	Max 35mm*	Max 35mm*
Y3	Max 60mm*	Max 60mm*
Y4	No front haunch	Max 100 (HB255 Max 50)
Minimum compressive strength	25 N/mm ²	25 N/mm ²

*Where regular HGV impacts are anticipated (e.g. roundabouts), we recommend that the concrete backing is laid to the top of the ACO KerbDrain® unit. (i.e. Y2=0, Y3=0)



These details are available to download in DWG or PDF format from the ACO website. Please [click here](#) to sign in or register to access this information.

Material benefits

The correct material selection for products installed in permanent works is extremely important to assure optimum performance throughout its design life.

ACO KerbDrain® is manufactured from Vienite®, ACO's sustainable high strength material. This material offers distinct advantages over other products and materials, addressing key specification and performance requirements for engineers and designers.



Sustainable use of materials

Efficient use of material resources is a key contributor to sustainability in construction. ACO KerbDrain® has been carefully designed to maximise strength while minimising material use.

- Vienite® combines the mechanical and performance benefits of synthetic resin concrete with high levels of recycled fillers.
- Vienite® is a sustainable material that contains in excess of 20% by weight post consumer waste previously destined for landfill in the UK.

• Vienite® fully conforms to and exceeds all performance requirements as specified by BS EN 1433:2002 for combined kerb drainage units.

• ACO KerbDrain® manufactured from Vienite® holds BSI Kitemark certification as a result of continuing independent verification of material performance by BSI.

• Vienite is recyclable, i.e. it can be collected, processed and returned for re-use as a raw material.

The ACO KerbDrain® range also includes components manufactured from ductile iron and steel which contain between 25% and 90% recycled material.

Model specification clause

The combined kerb drainage system shall be ACO KerbDrain® as supplied by ACO Technologies plc. All materials and components within the scope of the system shall be supplied by this manufacturer. The kerb drainage units shall be fully compliant with BS EN 1433:2002 with Initial Type Test certification issued by a notified body independent of the manufacturer and shall comply with the Manual of Contract Documents for Highway Works: Specification of Highway Works, Clause 516. The kerb drainage units shall be certified by a third party product certification system compliant with BS EN 45011:1998 carried out by an accredited body (UKAS or equivalent), e.g. Kitemark.

The ACO KerbDrain® HB255 units shall be of units of 80mm internal bore and 125mm external width, matching the profile of a standard HB2 kerb stone profile. The ACO KerbDrain® HB255, SP280, HB305, SP380, HB405, HB480 and SP480 shall be of 100mm internal bore and 150mm external width matching the profile of standard HB1, HB2 or SP kerb stones.

All units shall be of one piece manufacture from Vienite® resin concrete with minimum recycled content of 20% by weight. The units shall have four inlet holes per metre run of kerb, with a minimum inlet area of 14,730mm² per m.

The standard units shall be installed with the manufacturer's drop kerbs, centre stones, gullies, access units, radius and mitred units and accessories as required for the scheme. The system shall be installed in accordance with the manufacturer's printed recommendations, and the works carried out as specified on drawings (*) and in accordance with recognised good practice. Standards of workmanship shall generally be as specified in BS EN 752 and BS8000:Part 14:1989.

*Please insert drawing no. relevant to the project.

Highways Specification – Appendix 5/5

The Appendix 5/5 will need to be completed for each project. A model Appendix 5/5 for ACO KerbDrain® is available from the ACO Water Management Design Services Team.

NBS Specification

ACO KerbDrain® should be specified in section Q10:190. Assistance in completing this clause can be found in ACO Technologies product entries in NBS Plus or a model specification can be downloaded [here](#). For further assistance, contact the ACO Water Management Design Services Team.

MECHANICAL PROPERTIES OF VIENITE®

The following data compares the advantages of Vienite® used to manufacture ACO KerbDrain® with Ordinary Portland Cement (OPC) concrete and recycled plastic composite materials.

Compressive strength

Vienite® has high compressive strength is therefore extremely resistant to service loads.

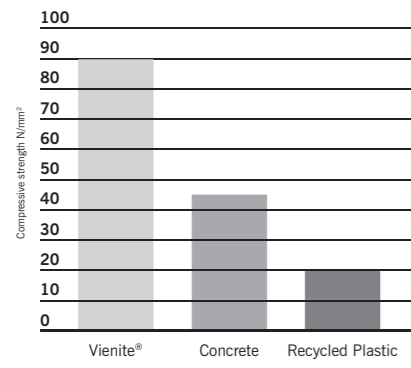

Impact Resistance

ACO KerbDrain's optimised design combined with the nature of Vienite®, makes it highly resistance to damage typically caused during installation or from traffic impacts. ACO KerbDrain® has been proven to be 50% more resistant to impact damage than traditional OPC concrete kerb stones*.

Flexural Strength

Vienite® has excellent flexural strength making the product resistant to side loads typically encountered during surfacing and installation.

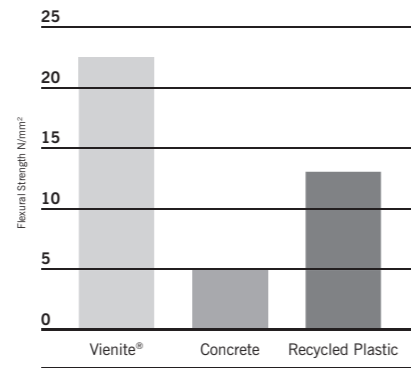

Water absorption

Vienite® has low water absorption of only 0.01% by weight which means surface water or liquids are contained within the product until discharge without contaminating surrounding soil or groundwater.

Coefficient of Friction (Mannings)

Vienite® is extremely smooth having a Mannings coefficient of 0.011 giving enhanced hydraulic performance and resisting the build up of silt and debris.

Coefficient of Thermal Expansion

Vienite® has a low coefficient of thermal expansion making it extremely stable, and unlike some materials it will not buckle or distort if subjected to high or low temperatures during service.

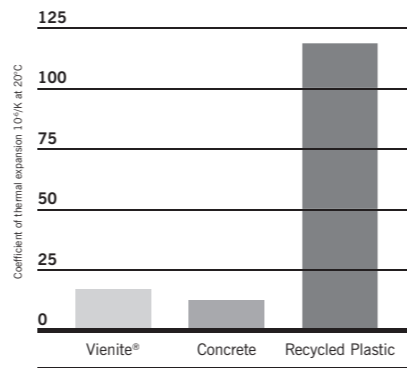

Chemical Resistance

Vienite® has high resistance to dilute acids and alkalis and is unaffected by road salts, fuels and oils which are typically encountered during service. For a copy of our full chemical resistance chart for Vienite® please contact our ACO Water Management Design Services Team.

Conformity

The ACO KerbDrain® system is CE marked in accordance with the Construction Products Regulation.

Declarations of Performance are available via the [CPR Zone](#) on our website, or on request. Please contact ACO Water Management Design Services Team on 01462 816666 for further assistance.

BS EN 1433:2002



*Tested by Birmingham City Laboratories (BCL)

Surface water management cycle

To help architects, designers and contractors meet the legal requirements that now tightly control the way surface water is managed; ACO has created its unique 'Surface Water Management Cycle' – **Collect, Clean, Hold, Release** – the four core processes now required for the complete and sustainable management of surface water drainage.

[Find out more.](#)



The ACO Group: A strong family you can depend on.

Contact us

If you need further product, design or installation advice on the ACO KerbDrain® or any other ACO system, please [click here](#) for a list of our key contacts.

Follow us

For the latest ACO News and product information follow us on [LinkedIn](#) and [Twitter](#).



Standards & Accreditations

[Click here](#) for details.



This brochure has been specifically prepared to be viewed digitally.
Please consider the environment and do not print this brochure unless you really need to.

© July 2013 ACO Technologies plc. All reasonable care has been taken in compiling the information in this document. All recommendations and suggestions on the use of ACO products are made without guarantee since the conditions of use are beyond the control of the Company. It is the customer's responsibility to ensure that each product is fit for its intended purpose, and that the actual conditions of use are suitable. This brochure and any advice is provided by ACO Technologies plc (the Company) free of charge and accordingly on terms that no liability including liability for negligence will attach to the Company or its servants or agents arising out of or in connection with or in relation to this brochure or any such advice. Any goods supplied by the Company will be supplied solely upon its standard conditions of sale, copies of which are available on request. The Company's policy of continuous product development and improvement renders specifications liable to modification. Information provided in this brochure is therefore subject to change without prior notification.